

## 57BYGH633 步进电机

电机型号 Model	步矩角 Step angel (°)	机身 长 Motor Lengt h L(mm)	相电压 Rate Voltage (V)	相电流 Rate Current (A)	相电阻 Phase Resistanc e (Ω)	相电感 Phase Inductanc e (mH)	静力矩 Holdin g Torque (kg. cm )	引线 数 Lead Wire (NO. )	转动惯 量 Rotor Inerti a (g. c m <sup>2</sup> )	定位力 矩 Detent Torque (kg. cm )	重量 Motor Weigh t (kg)
57BYGH001	1.8	41	6	0.5	12	20	4	4	120	0.21	0.45
57BYGH013	1.8	41	2.7	1.5	1.8	4	4	4	120	0.21	0.45
57BYGH201	1.8	51	7.2	0.6	12	25	7	4	275	0.36	0.65
57BYGH206	1.8	51	6.6	1	6.6	8.2	7.2	6	275	0.36	0.65
57BYGH218	1.8	51	2.6	2	1.3	4	9	4	275	0.36	0.65
57BYGH402	1.8	56	12	0.6	20	25	8	6	300	0.4	0.7
57BYGH420	1.8	56	3.6	2	1.8	2.5	9	6	300	0.4	0.7
57BYGH502	1.8	67	3.4	2	1.7	3	10	6	360	0.5	0.82
57BYGH506	1.8	67	2.4	3	0.8	1	9	6	360	0.5	0.82
57BYGH603	1.8	78	8.6	1	8.6	18	14.5	6	480	0.68	1
57BYGH633	1.8	78	3	3	1	1.6	13.5	6	480	0.68	1
57BYGH800	1.8	84	7.5	1.5	5	10	16	8	530	0.65	1.13
57BYGH115-003	1.8	115	6.3	3	2.1	9	25	4	810	0.89	1.55
57BYGH115-007	1.8	115	4.2	4.2	1	2.3	19.5	8	810	0.89	1.55

## Mechanical Dimensions

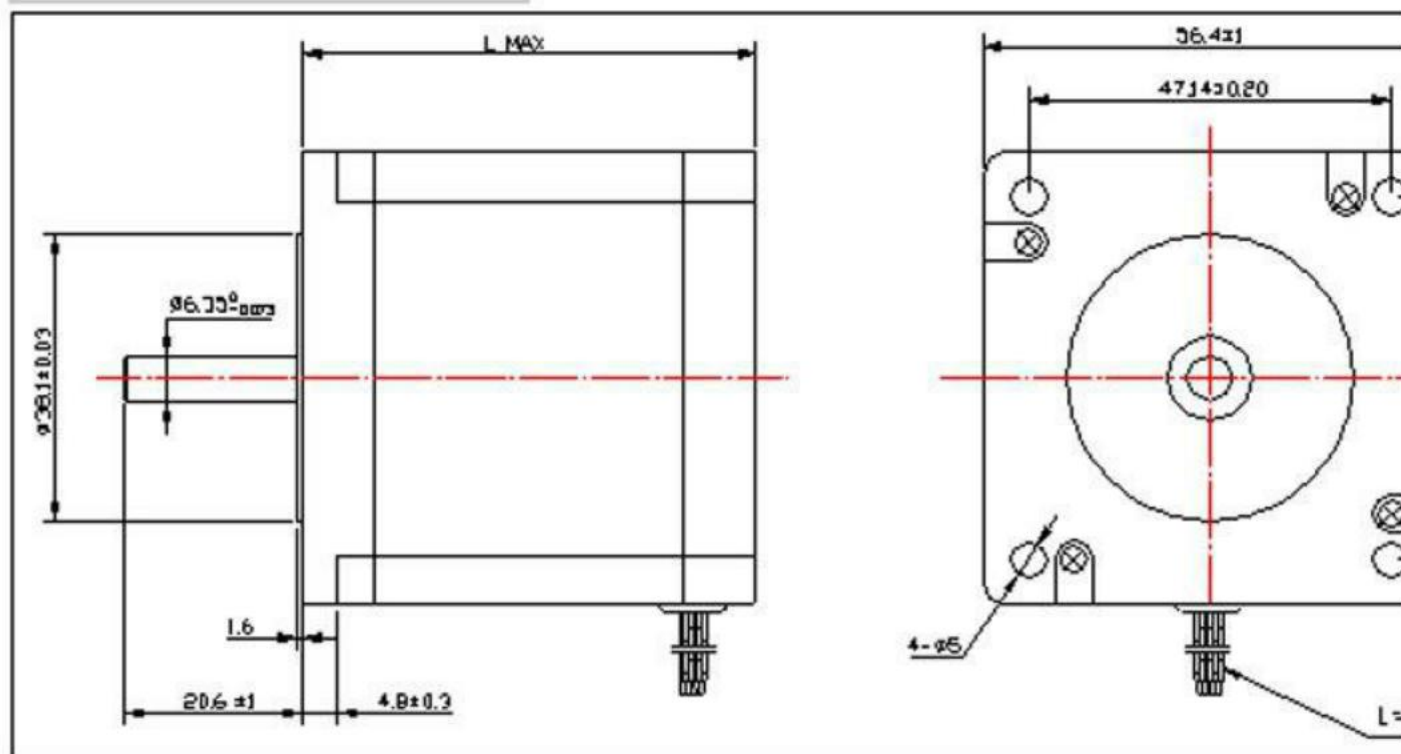

## Wiring Diagram

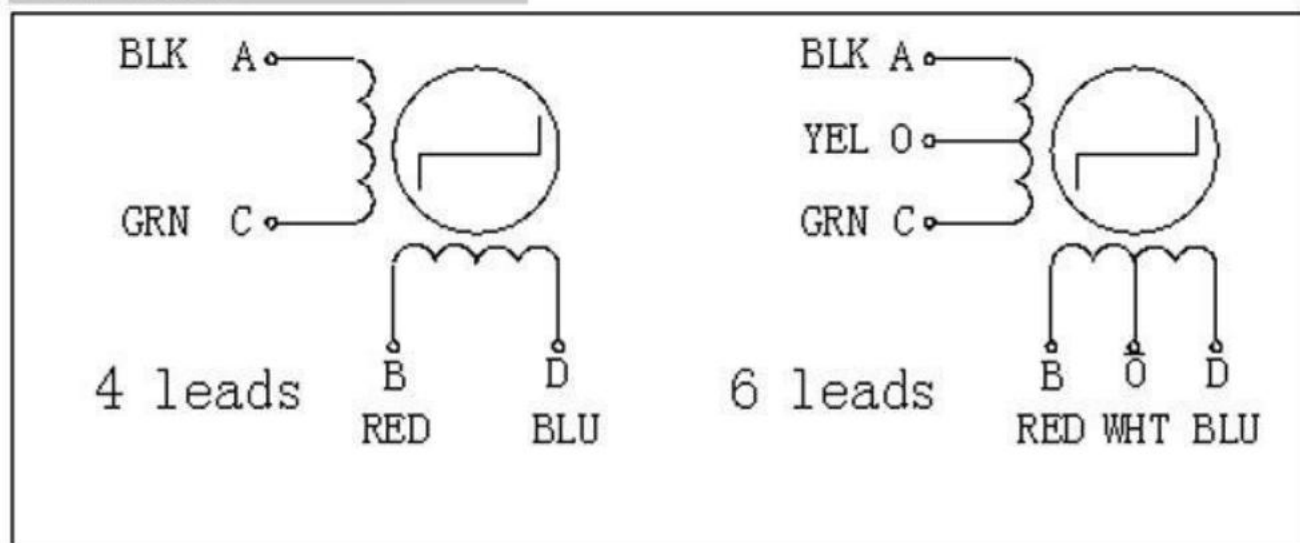

## Pulse-torque Characteristics

