



GPON ONU Optical Transceiver SFF Module

RTXM167-407

Features

- *Integrated Single fiber bi-directional optical subassembly*
- *1310nm DFB laser Burst-mode Transmitter and 1490nm APD Continuous receiver(with WDM)*
- *SFF 2×10 metallic package*
- *+3.3V single power supply*
- *Low power consumption*
- *0 to 70°C operating case temperature*
- *LVPECL compatible data input*
- *CML compatible data output*
- *LVTTL transmitter burst mode control*
- *Burst Enable: L-active*
- *LVTTL receiver signal-detected indication*
- *Class 1 Laser eye safety*
- *Excellent EMI and EMC characteristics*
- *DDM Function implemented*
- *Compliant with RoHs&WEEE*

Applications

- *Optical transceiver for Gigabit-capable Passive Optical Networks (GPON) ONU side*

Standards

- *ITU-T G.984.2 Class B+*
- *Small Form Factor Transceiver Multisource Agreement July 5, 2000*
- *Compliant with SFF-8472 v9.5*

Description

The GPON ONU Transceiver is designed for Gigabit-capable Passive Optical Network (GPON) transmission. The module incorporates 1310nm burst-mode transmitter and 1490nm continuous-mode receiver.

The transmitter section uses a 1310nm DFB laser and an integrated BM laser driver which is designed to perform very small burst enable/disable delay time. The laser driver also includes digital APC and temperature compensation circuit, which are used for keeping the launch optical power and extinction ratio constant over temperature and aging.

The receiver section uses an integrated 1490nm APD photodiode and preamplifier mounted together. It has the function that indicates receiver signal-detected status (active high).

An integrated WDM coupler can separate 1490nm input light and 1310nm output light.

The metallic package guarantees excellent EMI and EMC characteristics, which totally comply with international relevant standards.

Absolute Maximum Ratings

Parameter	Symbol	Unit	Min	Max
Operating Case Temperature Range	T _c	°C	0	70
Storage Temperature Range	T _s	°C	-40	85
Relative Humidity	RH	%	5	95
Power Supply Voltage	V _{cc}	V	0	4.6
Pin Input Voltage		V	GND	V _{cc}
Receiver Damage Threshold		dBm	+4	–
Lead Solder Temperature		°C	–	260
Lead Solder Duration		S	–	10
Fiber Yield Strength		k _{gf}	–	0.5
Fiber Bend Radius		mm	30	–

Recommended Operating Conditions

Parameter	Symbol	Unit	Min	Typ	Max
Operating Voltage	V_{CC}	V	3.13	3.3	3.47
Operating Case Temperature Range	T_c	°C	0	-	70

Specifications ($0^{\circ}\text{C} < T_c < 70^{\circ}\text{C}$ and $3.13\text{V} < V_{CC} < 3.47\text{V}$)

Parameter	Symbol	Unit	Min	Typ	Max	Notes
Electrical Characteristics						
Supply Current	I_{CC}	mA	-	-	300	
LVPECL Single Ended Data Input Swing		mV	100	-	1200	1
CML Single Ended Data Output Swing		mV	400	-	600	2
Differential Data input impedance	Ω		-	100	-	1
Signal Level(LVTTL H)		V	2.4	-	V_{CC}	
Signal Level(LVTTL L)		V	0	-	0.8	
Optical transmitter Characteristics						
Data Rate		Mbps	-	1244.16	-	
Center Wavelength Range	λ_c	nm	1290	-	1330	
Spectral Width(@-20dB)	$\Delta\lambda$	nm	-	-	1	
Launch Optical Power	P_o	dBm	0.5	-	+5	3
Off level light		dBm	-	-	-45	
Extinction Ratio	EX	dB	10	-	-	4
Burst turn on/off time	Ton/Toff	ns	-	-	12	5
Rise/Fall time(20%~80%)	Tr/Tf	ps	-	-	260	6
RIN ₁₅ OMA		dB/Hz	-	-	-115	
Optical Return Loss Tolerance		dB	-	-	15	
Maximum reflectance		dB	-	-	-12	$\lambda=1.31\mu\text{m}$
Transmitter dispersion penalty	TDP	dB	-	-	1	7
Eye Diagram	Compliant with	ITU-T G.984.2				8
Optical receive Characteristics						
Data Rate		Mbps	-	2488.32-	-	
Receiver Sensitivity	S	dBm	-	-	-28	9
Overload Input Optical Power	P_{in}	dBm	-7	-	-	9
Center Wavelength Range	λ_c	nm	1480	1490	1500	
Receiver reflectance		dB	-	-	-20	$\lambda=1.49\mu\text{m}$
SD(LVTTL)	Optical Dessert	dBm	-44	-	-	
	Optical Assert		-	-	-30	
SD Hysteresis		dB	0.5	-	6	

Note1: DC coupled internally and terminated internally (see the recommended circuit below).

Note2: CML output, AC coupled internally (see the recommended circuit below).

Note3: Coupled into 9/125 SMF

Note4: Measured with PRBS 2²³-1 test pattern @1.25Gbps.

Note5: see Figure 1.

Note6: Measured with the Bessel-Thompson filter ON.

Note7: Transmit on 20km SMF.

Note8: See Figure 2.

Note9: Measured with PRBS 2²³-1 test pattern @2.5Gbps with Tx on, ER=10dB, BER=10E-12.

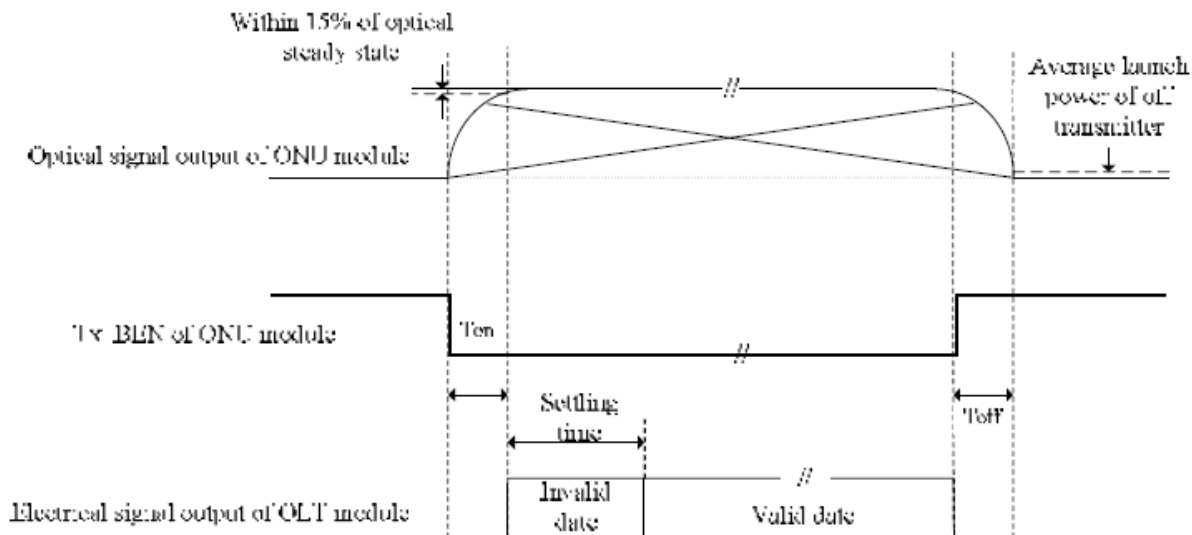

Figure1 Burst_mode Receiver Dynamic range in GPON system

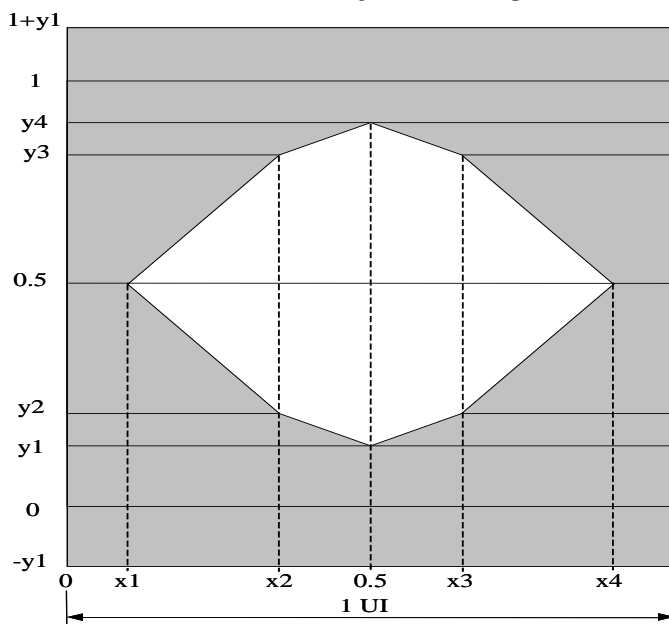
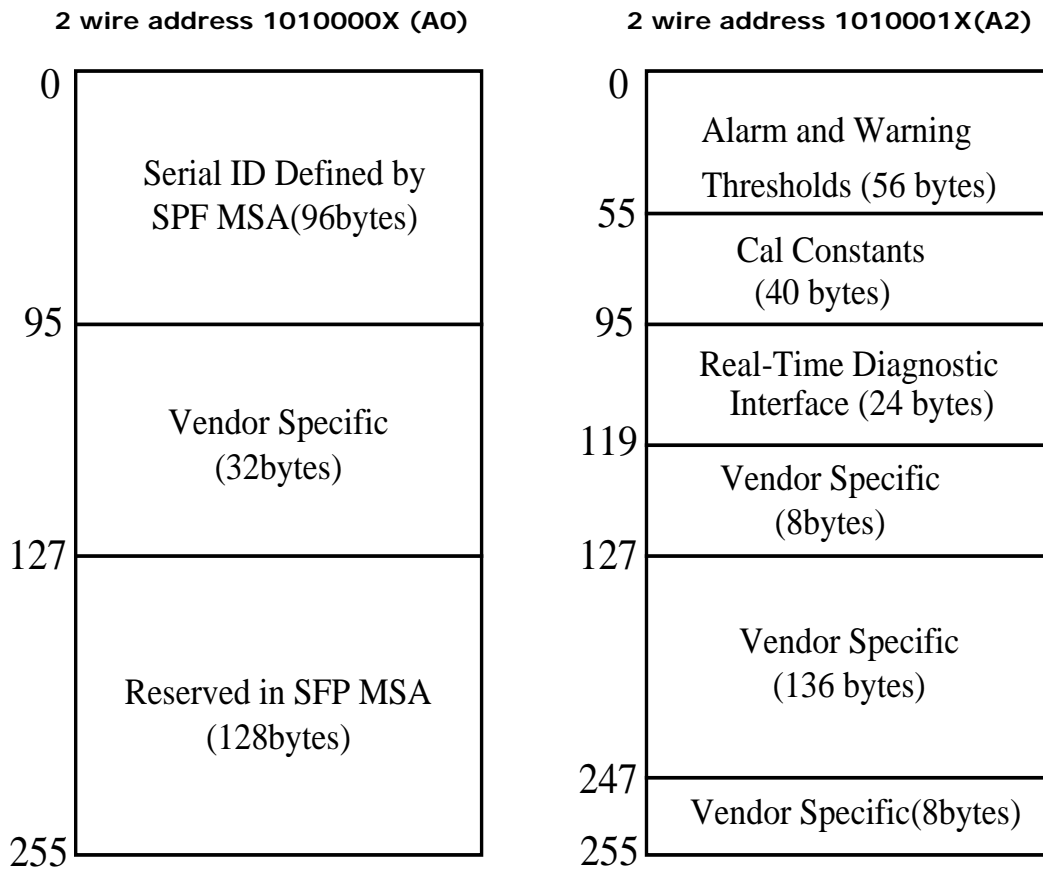

Figure2 Mask of diagram

	155.52 Mbit/s	622.08 Mbit/s	1244.16 Mbit/s	2488.32 Mbit/s
x1/x4	0.10/0.90	0.20/0.80	0.22/0.78	For further study
x2/x3	0.35/0.65	0.40/0.60	0.40/0.60	For further study
y1/y4	0.13/0.87	0.15/0.85	0.17/0.83	For further study
y2/y3	0.20/0.80	0.20/0.80	0.20/0.80	For further study

Digital Diagnostic Memory Map



EEPROM Serial ID Memory Contents

Accessing Serial ID Memory uses the 2 wire address 1010000X (A0). Memory Contents of Serial ID are shown in the Table 1.

Table 1 Serial ID Memory Contents

Data Address (Bytes)	Size (Bytes)	Name of Field	Contents(Hex)	Description
BASE ID FIELDS				
0	1	Identifier	02	Module/connector soldered to motherboard
1	1	Extended. Identifier	FF	Reserved
2	1	Connector	0B	Optical pigtail
3-10	8	Transceiver		Transceiver Codes
11	1	Encoding	03	NRZ
12	1	BR, Nominal	00	
13	1	Reserved	00	
14	1	Length (9μm) km	14	Transceiver transmit distance

15	1	Length (9μm) 100m	C8	
16	1	Length (50μm) 10m	00	
17	1	Length(62.5μm)10m	00	
18	1	Length (Copper)	00	Not compliant
19	1	Reserved	00	
20-35	16	Vendor name	57 54 44 20 20 20 20 20 20 20 20 20 20 20 20 20	"WTD"(ASCII)
36	1	Reserved	00	
37-39	3	Vendor OUI	00 00 00	
40-55	16	Vendor PN		Transceiver part number
56-59	4	Vendor rev	20 20 20 20	
60-61	2	Wavelength	00	Transceiver wavelength
62	1	Reserved	00	
63	1	CC_BASE	Check Sum (Variable)	Check code for Base ID Fields
EXTENDED ID FIELDS				
64-65	2	Options	00 00	TX_DISABLE, TX_FAULT and Loss of Signal not implemented.
66	1	BR,max	00	
67	1	BR,min	00	
68-83	16	Vendor SN	42 30 30 39 38 32 32 20 20 20 20 20 20 20 20 20	Serial Number of transceiver (ASCII). For example "B009822".
84-91	8	Date code	30 32 31 30 30 35 20 20	Manufactory date code. For example "021005".
92	1	Diagnostic Monitoring Type	68	Digital diagnostic monitoring implemented, "internally calibrated" is implemented, RX measurement type is "Average Power".
93	1	Enhanced Options	B0	Optional Alarm/Warning flags implemented for all monitored quantities, Optional Soft TX_FAULT monitoring implemented, Optional Soft RX_LOS monitoring implemented.
94	1	SFF_8472 Compliance	03	Includes functionality described in Rev9.5 SFF-8472.
95	1	CC_EXT	Check Sum (Variable)	Check sum for Extended ID Field.
VENDOR SPECIFIC ID FIELDS				
96-127	32	Vendor Specific	Read only	Depends on customer information
128-255	128	Reserved	Read only	Filled by zero

Table 3 Memory contents of Diagnostic Monitor Function

Data Address	Field Size (bytes)	Name	Contents and Description
Alarm and Warning Thresholds			
00-01	2	Temperature High Alarm	Set to 80 °C
02-03	2	Temperature Low Alarm	Set to -10°C
04-05	2	Temperature High Warning	Set to 70 °C
06-07	2	Temperature Low Warning	Set to 0 °C
08-09	2	Vcc High Alarm	Set to 3.6 V
10-11	2	Vcc Low Alarm	Set to 3.0 V
12-13	2	Vcc High Warning	Set to 3.5 V
14-15	2	Vcc Low Warning	Set to 3.1 V
16-17	2	Bias High Alarm	75mA
18-19	2	Bias Low Alarm	2 mA
20-21	2	Bias High Warning	60 mA
22-23	2	Bias Low Warning	5 mA
24-25	2	TX Power High Alarm	7.0dbm
26-27	2	TX Power Low Alarm	-2.0dbm
28-29	2	TX Power High Warning	5.0dbm
30-31	2	TX Power Low Warning	0dbm
32-33	2	RX Power High Alarm	-8.0dbm
34-35	2	RX Power Low Alarm	-28.0dbm
36-37	2	RX Power High Warning	-11.0dbm
38-39	2	RX Power Low Warning	-25.0dbm
40-55	16	Reserved	
Calibration Constants			
56-59	4	RX Power Calibration Data4	00 00 00 00 (fixed)
60-63	4	RX Power Calibration Data3	00 00 00 00 (fixed)
64-67	4	RX Power Calibration Data2	00 00 00 00 (fixed)
68-71	4	RX Power Calibration Data1	3F 80 00 00 (fixed)
72-75	4	RX Power Calibration Data0	00 00 00 00 (fixed)
76-77	2	Bias Calibration Data1	01 00 (fixed)
78-79	2	Bias Calibration Data0	00 00 (fixed)
80-81	2	TX Power Calibration Data1	01 00 (fixed)
82-83	2	TX Power Calibration Data0	00 00 (fixed)
84-85	2	Temperature Calibration Data1	01 00 (fixed)
86-87	2	Temperature Calibration Data0	00 00 (fixed)
88-89	2	Vcc Calibration Data1	01 00 (fixed)
90-91	2	Vcc Calibration Data0	00 00 (fixed)
92-94	3	Reserved	00 00 00 (fixed)

95	1	Check Sum	Checksum of bytes 0-94
Real Time Diagnostic Monitor Interface			
96-97	2	Measured Temperature	Yield a 16-bit A/D value (see Table 3.1)
98-99	2	Measured Vcc	Yield a 16-bit A/D value (see Table 3.1)
100-101	2	Measured Bias	Yield a 16-bit A/D value (see Table 3.1)
102-103	2	Measured TX Power	Yield a 16-bit A/D value (see Table 3.1)
104-105	2	Measured RX Power	Yield a 16-bit A/D value (see Table 3.1)
106-109	4	Reserved	
110	1	Logic Status	See Table 3.2
111	1	AD Conversion Updates	See Table 3.2
112-119	8	Alarm and Warning Flags	See Table 3.3
Vendor Specific			
120-127	8	Vendor Specific	Don't Access
128-247	120	User writable EEPROM	
248-255	8	Vendor Specific	Don't Access

The measured values located at bytes 96-105 (in the 2 wire address 0xA2) are raw A/D values (16-bit integers) of transceiver temperature, supply voltage, laser bias current, laser optical output power and received power. All the measured values are "Externally Calibrated", and then it is necessary to convert raw A/D values to real world units by the manner as shown in Table 3.1.

Table 3.1 Real Time Diagnostic Monitor Values

Byte Name	Description
96 Temperature MSB	Internally measured transceiver temperature. Compliant with External Calibration of SFF-8472.
97 Temperature LSB	
98 Vcc MSB	Internally measured supply voltage. Compliant with External Calibration of SFF-8472.
99 Vcc LSB	
100 Laser Bias MSB	Measured Laser bias current. Compliant with External Calibration of SFF-8472.
101 Laser Bias LSB	
102 Tx Power MSB	Measured Tx power. Compliant with External Calibration of SFF-8472.
103 Tx Power LSB	
104 Rx Power MSB	Measured Tx power. Compliant with External Calibration of SFF-8472.
105 Rx Power LSB	

This transceiver implements two optional status bytes, "Logic States" at byte 110(0xA2)" and "A/D Updated" at byte 111(0xA2) as shown in Table 3.2. "A/D Updated" status bits allow the user to verify if an update from the analog-digital conversion has occurred of the measured values, temperature, Vcc, laser bias, Tx power and Rx power. The user writes the byte to 0x00. Once a conversion is completed for a given value, its bit will change to '1'.

Table 3.2 Logic Status and AD Conversion Updates

Byte	Bit	Name	Description
110	7	Reserved	.
110	6	Soft Tx Disable Control	1= disable, 0= enable.

110	5	Reserved	Set to 0.
110	4	Rx Rate Select State	Not supported (set to 0).
110	3	Soft Rate Select Control	Not supported (set to 0).
110	2	Tx Fault	Not supported (set to 0).
110	1	LOS	Not supported (set to 0).
110	0	Power on Logic	Not supported (set to 0).
111	7-0	Temp A/D Valid	Set to 0.

Each of the measured values has a corresponding high alarm, low alarm, high warning and low warning threshold level at location 00-39(x0A2) written as the data format of a corresponding valued shown in Table 3.3. Alarm and warning flags at bytes 112-119(0xA2) are defined as follows.

- (1) Alarm flags indicate conditions likely to result (or have resulted) in link failure and cause for immediate action.
- (2) Warning flags indicate conditions outside the guaranteed operating specification of transceiver but not necessarily causes of immediate link failures.

Table 3.3 Alarm and Warning Flags

Byte	Bit(s)	Name	Description
112	7	Temperature High Alarm	Set when temperature monitor value exceeds high alarm level.
112	6	Temperature Low Alarm	Set when temperature monitor value exceeds low alarm level.
112	5	Vcc High Alarm	Set when Vcc monitor value exceeds high alarm level.
112	4	Vcc Low Alarm	Set when Vcc monitor value exceeds Low alarm level.
112	3	Laser Bias High Alarm	Set when laser bias monitor value exceeds high alarm level.
112	2	Laser Bias Low Alarm	Set when laser bias monitor value exceeds low alarm level.
112	1	Tx Power High Alarm	Set when Tx power monitor value exceeds high alarm level
112	0	Tx Power Low Alarm	Set when Tx power monitor value exceeds low alarm level.
113	7	Rx Power High Alarm	Set when Rx power monitor value exceeds high alarm level
113	6	Rx Power Low Alarm	Set when Rx power monitor value exceeds low alarm level
113	5-0	Reserved	All bits set to 0.
114	7-0	Reserved	All bits set to 0.
115	7-0	Reserved	All bits set to 0.
116	7	Temperature High warning	Set when temperature monitor value exceeds high warning level.
116	6	Temperature Low warning	Set when temperature monitor value exceeds low warning level.
116	5	Vcc High warning	Set when Vcc monitor value exceeds high warning level.
116	4	Vcc Low warning	Set when Vcc monitor value exceeds Low warning level.
116	3	Laser Bias High warning	Set when laser bias monitor value exceeds high warning level.
116	2	Laser Bias Low warning	Set when laser bias monitor value exceeds low warning level.
116	1	Tx Power High warning	Set when Tx power monitor value exceeds high warning level
116	0	Tx Power Low warning	Set when Tx power monitor value exceeds low warning level.
117	7	Rx Power High warning	Set when Rx power monitor value exceeds high warning level
117	6	Rx Power Low warning	Set when Rx power monitor value exceeds low warning level
117	5-0	Reserved	All bits set to 0.
118	7-0	Reserved	All bits set to 0.

119 7-0 Reserved

All bits set to 0.

Pin Description

Pin Name	Description	Pin Name	Description
1	NC	11	Tx VCC Transmitter power supply
2	RGND Receiver ground	12	Tx GND Transmitter ground
3	RGND Receiver ground	13	Tx EN LVTTTL Transmitter burst mode control, "L": Tx ON
4	NC	14	TD ₊ LVPECL Data input ₊ (DC coupled and internal terminated)
5	NC	15	TD ₋ LVPECL Data input ₋ (DC coupled and internal terminated)
6	Rx GND Receiver ground	16	TGND Transmitter ground
7	Rx VCC Receiver power supply	17	SCL I ² C Serial Clock (LVTTTL)
8	SD LVTTTL Signal detect	18	SDA I ² C Serial Data (LVTTTL)
9	RD ₋ Receiver data output ₋ (AC coupled internally)	19	TX_FAULT Transmitter Fault (LVTTTL)
10	RD ₊ Receiver data output ₊ (AC coupled internally)	20	NC

Block Diagram

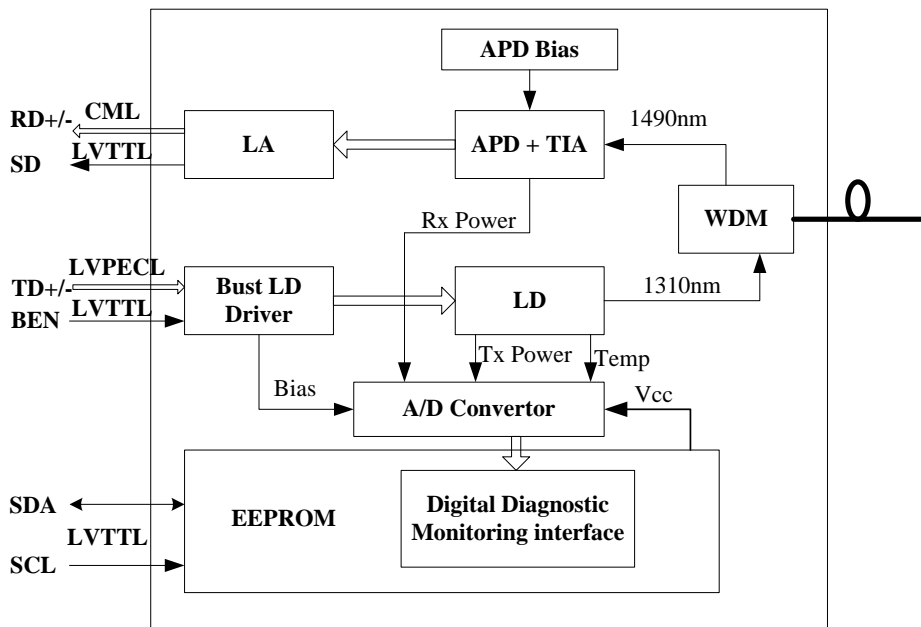

Figure3 Functional block diagram

Typical Application Circuit

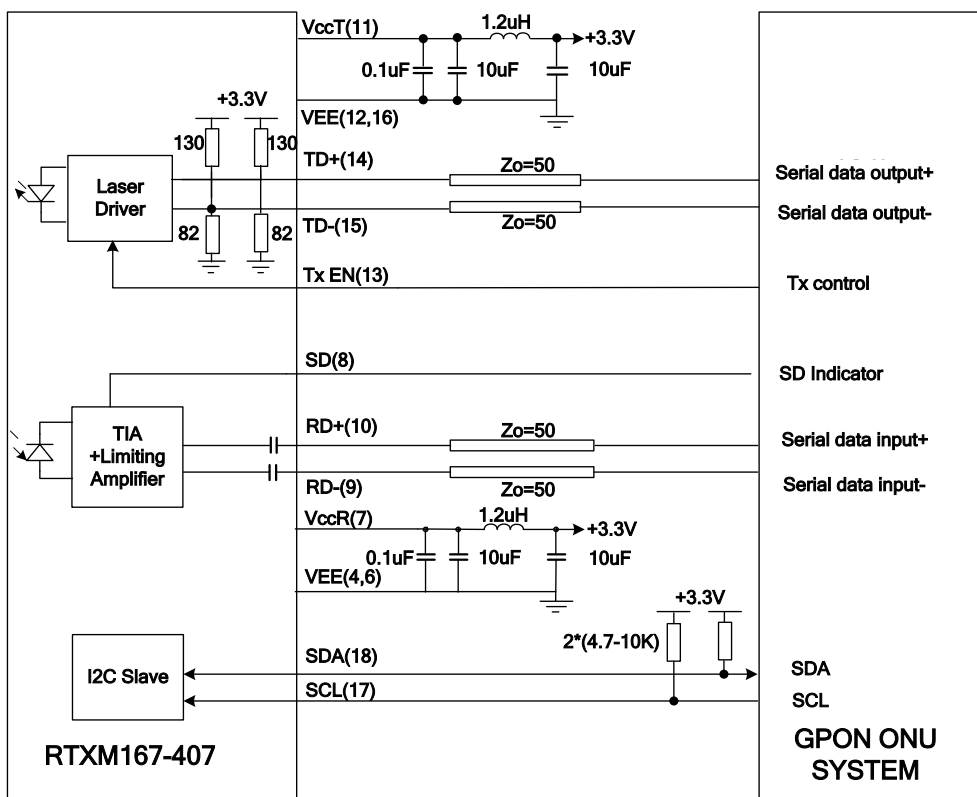

Figure4 Typical application circuit

Package Outline

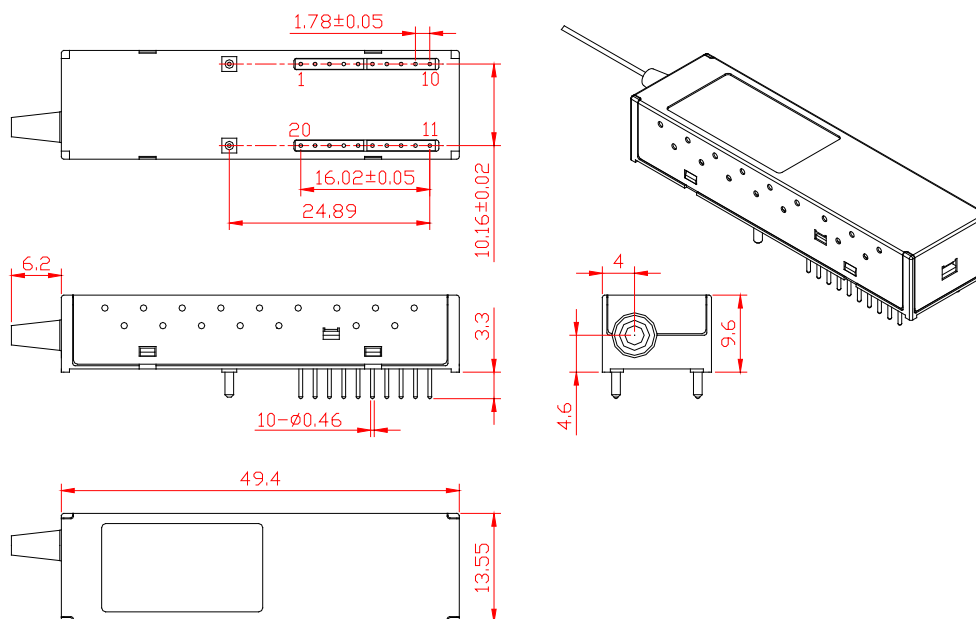

Figure5 Package outline

Regulatory Compliance

Feature	Test Method	Performance
Electrostatic Discharge (ESD) to the Electrical Pins	MIL-STD-883E Method 3015.7	Class 1 (>1.5kV) – Human Body Model
Electrostatic Discharge (ESD) Immunity	IEC61000-4-2	Class 2(>4.0kV)
Electromagnetic Interference (EMI)	CISPR22 Class B EN55022 Class B	ITE Compliant with standards
Immunity	IEC61000-4-3 Class 2 EN55024	Typically show no measurable effect from a 3V/m field swept from 80 to 1000MHz applied to the transceiver without a chassis enclosure.
Eye Safety	FDA 21 CFR 1040.10 and 1040.11 UL TUV EN 60825-1	Compliant with Class 1 laser product

Ordering Information

Part No.	Specification									Application
	Package	Datarate	Laser	Optical Power	Detector	Sensitivity	Temp	Reach	BM control logic	Code
RTXM167-407	SFF 2×10	1.25Gb/s US 2.5Gb/s DS	1310nm DFB	0.5 ~ 5dBm	APD	-28dBm	0~70°C	20km	L Enable	CLASSB+

Note1: SC/PC, SC/APC or other type of connector is optional by customer.

Note2: The length of pigtail is normal 1000±15mm (the length of connector is included), but can be customized for specific requirement.

WTD reserves the right to make changes to the product(s) or information contained herein without notice. No liability is assumed as a result of their use or application. No rights under any patent accompany the sale of any such product(s) or information.

Edition 2009-12-01

Published by Wuhan Telecommunication Devices Co.,Ltd.

Copyright © WTD

All Rights Reserved.