



CORTINA

Product Brief

Cortina Systems® CS4342 16-port 10G CDR with Octal EDC

Feature Benefits

- Small footprint (17 mm × 17 mm package)
 - Reduces valuable PCB real estate requirements in high density 10 GbE SFP+ and 40G QSFP+ line cards
- Low latency (less than a nanosecond)
 - Virtually eliminates the contribution of the PHY layer to the overall link latency
- Fully standards compliant
 - Compliant to 10 GbE, 40 GbE, 100 GbE, and 8/4/2/1G FC standards
 - Enables single line card design that supports all standards.

Applications

- 10G SFP+ line cards
- 40G QSFP line cards
- 10GBase-KR backplane
- 8/4/2/1G Fibre Channel Applications
- SONET/OTN line cards and backplanes
- CPRI links in 3G Basestations

Product Description

The Cortina Systems® CS4342 16-port 10G CDR with Octal EDC is an octal 10G Electronic Dispersion Compensation (EDC) device, which delivers low latency and standards compliance in the industry's smallest footprint. The CS4342 PHY 17 mm × 17 mm package is 34% smaller than other competitive devices available in the market, reducing valuable PCB real estate requirements in today's high density 10 GbE SFP+ and 40G QSFP+ line cards. It reduces latency, a critical parameter in data center and financial applications, to less than a nanosecond.

The CS4342 PHY incorporates the latest standards and technologies for 10G, 40G, and 100G optics and copper cables, including support for diverse standards such as 10Gbase-LRM, 10G Direct Attach Copper, 10GBase-ZR, DWDM, 40Gbase-SR4/LR4, and CR4 copper cables which allows equipment manufacturers to create one line card to support multiple applications.

The CS4342 PHY functionality supports eight full-duplex 10G links or two full-duplex 40G links. Both transmit and receive paths include Clock and Data Recovery (CDR) circuits. The device has a wide operating frequency range covering 1 GbE, 1G FC, 2G FC, 4G FC, 8G FC, SONET (9.5 - 11.3G), 10 GbE, and CPRI rates. EDC capability allows the device to operate with linear SFP+ optical modules to support 10Gbase-LRM, Direct Attach Copper, and 10GBase-ZR and DWDM SMF applications. The device is fully compliant to 10G SFP+ and 802.3ba 40G and 100G specifications. The transmit path includes a 10Gbase-KR compliant 3 tap transmit pre-emphasis capability. The transmit pre-emphasis in conjunction with the receive EDC enables the device to support 10Gbase-KR, 8G FC, and telecom backplane applications. The receive recovered clock can be brought on pins for SyncE applications. The device is fully autonomous and does not require external processors to control the initial convergence or the dynamic adaption of the dispersion compensation. In addition, the device includes extensive debug features and I/Os for device monitoring and control.

Features

- Fully standards compliant:
 - IEEE 802.3ba nPPI and nAUI specifications
 - IEEE 802.3aq
 - SFF-8431 SFP+ specifications
- Wide operating data range:
 - 10, 40 GbE, and SONET: 9.983 – 11.3 Gbps
 - Fibre Channel: 8.5 Gbps, 4.25 Gbps, 2.125 Gbps and 1.0625 Gbps
 - RXAUI/XAUI: 6.25 Gbps, 3.125 Gbps
 - Infiniband: 10 Gbps, 5 Gbps, 2.5 Gbps
 - CPRI: 9.983 Gbps, 6.144 Gbps, 4.915 Gbps, 3.072 Gbps, 2.457 Gbps, 1.2288 Gbps, 614 Mbps
- Receive EDC that exceeds standards requirements:
 - 10GBase-LRM
 - SFF-8431 Direct Attach Copper, and 40GBase-CR4
 - SFP+ ZR and DWDM
- Extensive test and monitoring capabilities:
 - PRBS generators and checkers
 - Programmable pattern generator
 - Shared interrupt, and per port GPIOs with user programmable functionality
 - 1149 AC-JTAG support

CS4342 EDC PHY

Block Diagram

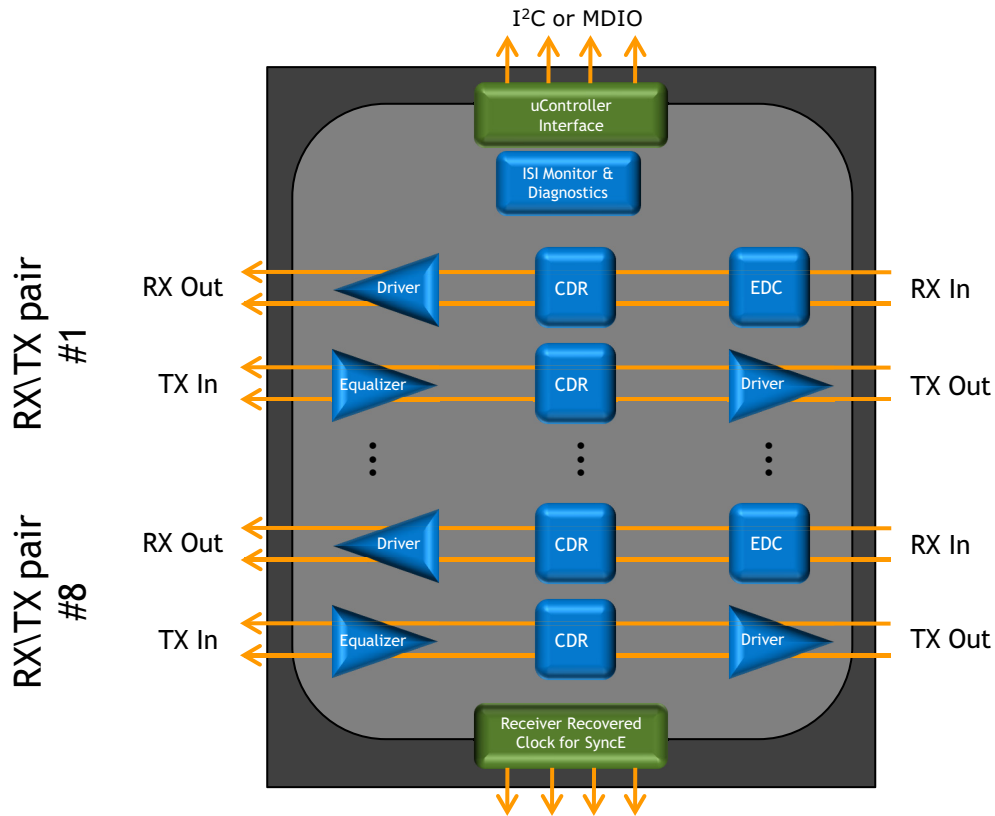

Cortina in Communications

Cortina Systems, Inc. is a leading provider of high-performance communications semiconductor solutions enabling next generation network connectivity and efficient bandwidth from the core network to the home

network. Our broad product portfolio includes carrier-class semiconductor devices for next generation optical transport and passive optical network systems, as well as data center connectivity and digital home solutions.

*Other names and brands may be claimed as the property of others.



CORTINA

Cortina Systems, Inc.
www.cortina-systems.com