

# 100Gb/s & Beyond Ethernet Optics

---

From Gigabit to Terabit Ethernet  
Ethernet Alliance Panel  
OFC / NFOEC 2012  
Los Angeles, CA  
7 March 2012  
Chris Cole

# Outline

---

- 100GE Gen1 Optics & Modules
- 100GE Next Gen Optics & Modules
- 400GE Optics & Modules

# 100GE Gen1 Optics: LR4 & SR10

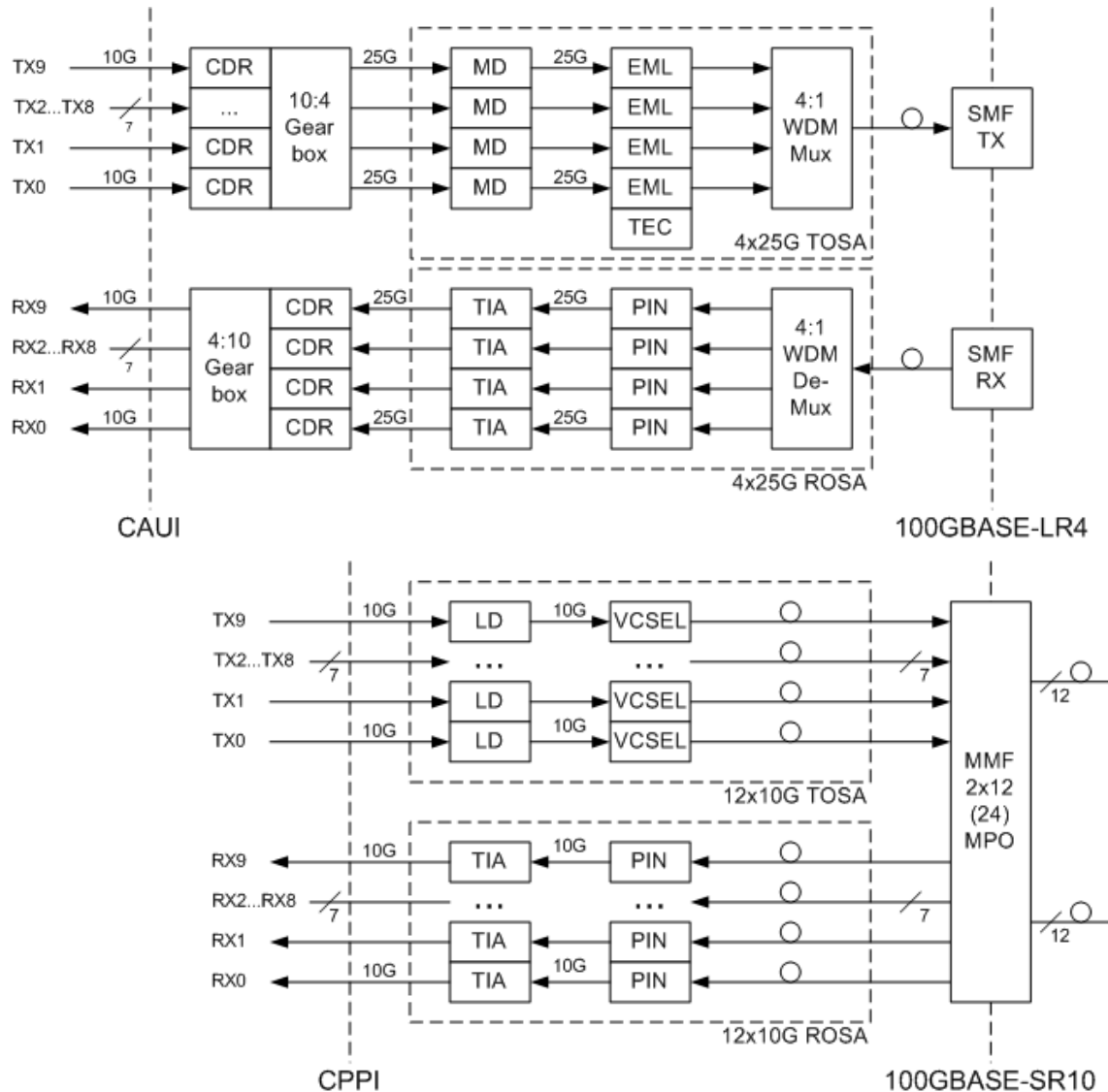

# 100GE Gen1 Modules: CFP & CXP



CFP I/O: 10x 10G (CAUI)

CXP I/O: 10x 10G (CPPI) MMF only

# 100GE Next Gen Optics: LR4 & SR4

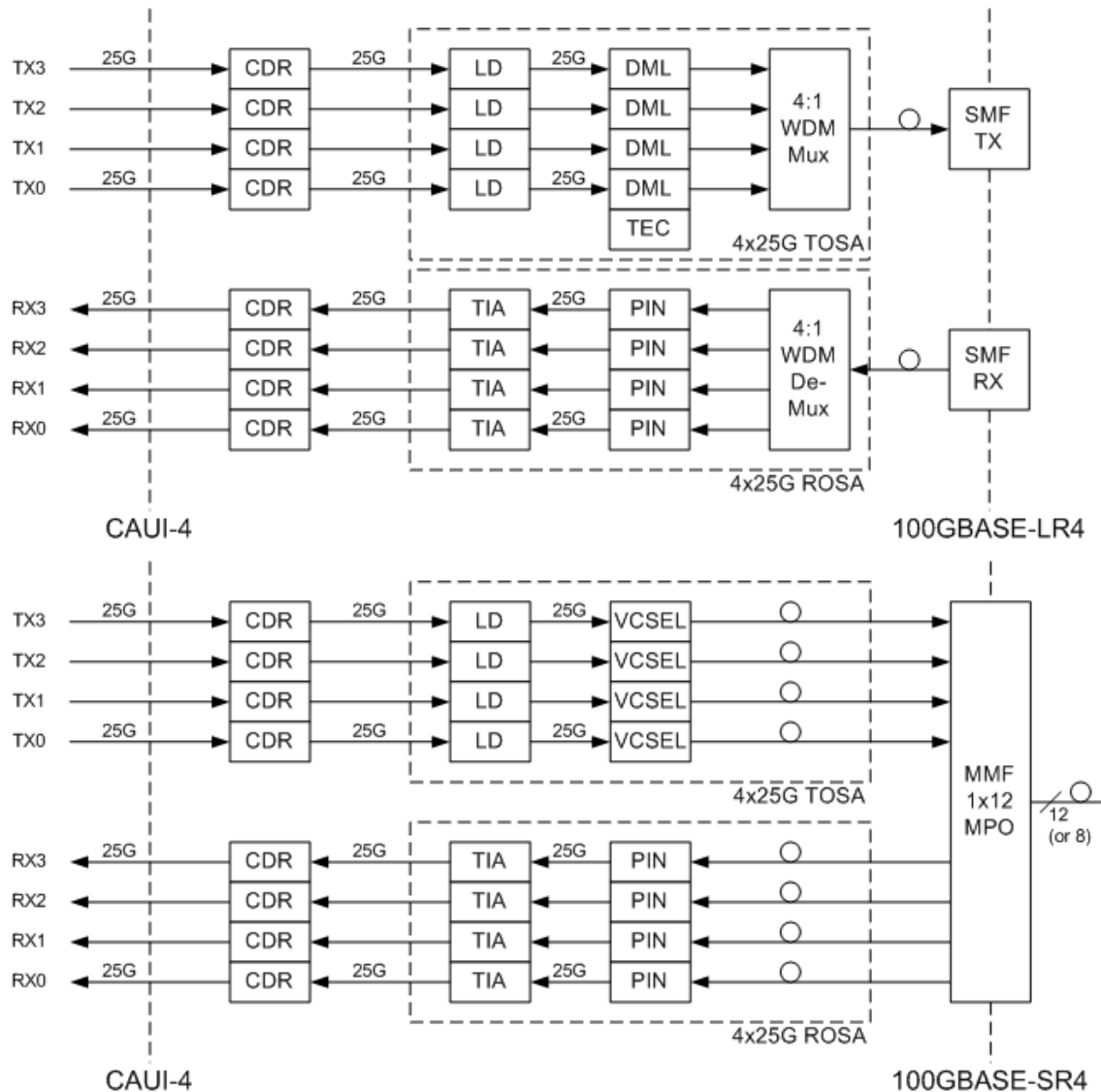

# 100GE Modules: CFP, CFP2, CFP4

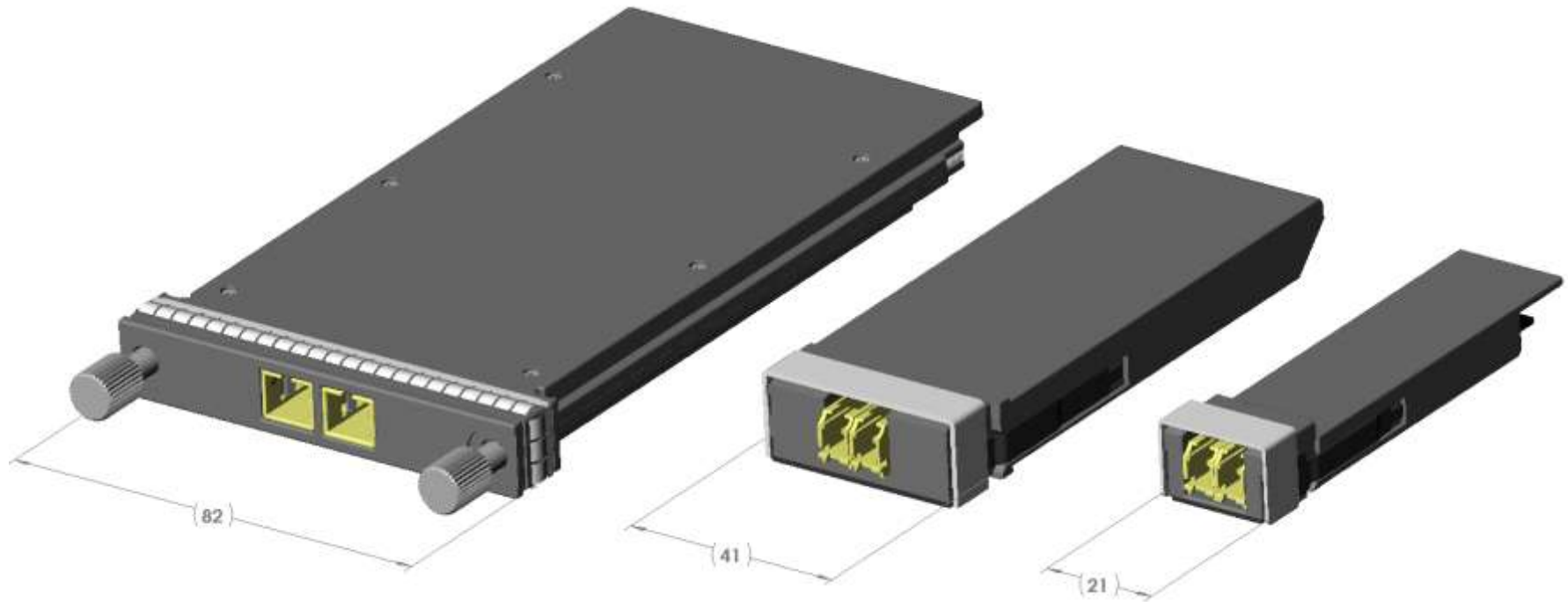

CFP I/O: 10x 10G (CAUI), ~20W typical LR4

CFP2 I/O: 4x 25G (CAUI-4) & 10x10G (CPPI), ~8W typ. LR4

CFP4 I/O: 4x 25G (CAUI-4), ~5W typical LR4

# 400GE Gen1 Optics: nR16 & SR16

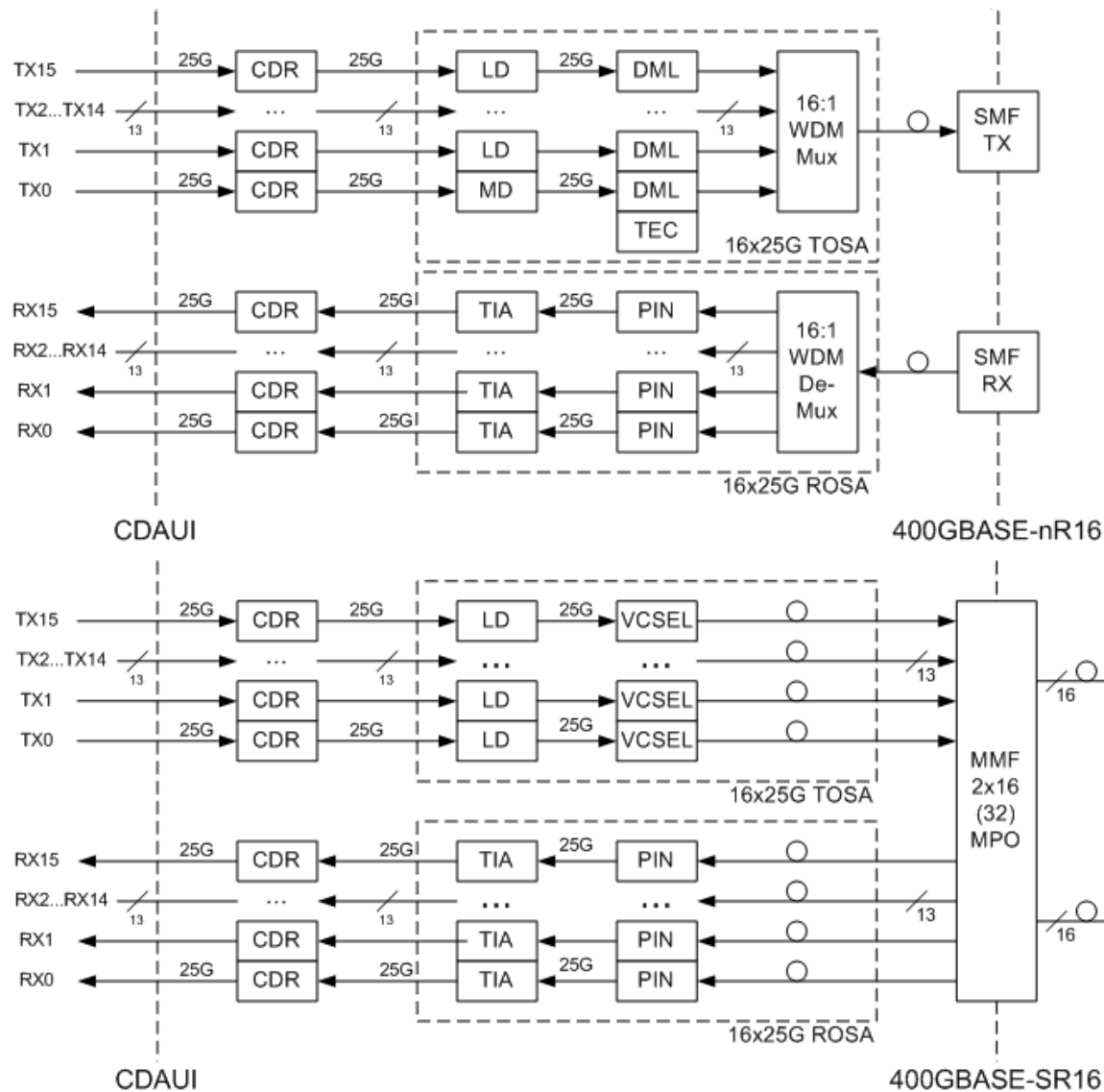

# 400GE Modules: CFP4x4, CFP2, CXP4x4



CFP4x4 I/O: 16x 25G (CDAUI, NRZ)

CFP2 I/O: 8x 50G (CDAUI-8, PAM-4 or NRZ)

CXP4x4 I/O: 16x 25G (CDPPI, NRZ) MMF only