

## BRR – Tektronix BroadR-Reach Compliance Solution for Automotive Ethernet

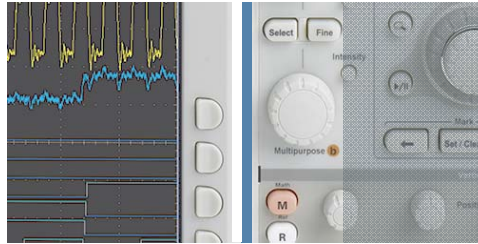

Anshuman Bhat – Product Manager  
anshuman.bhat@tektronix.com



### Agenda

- BroadR-Reach
  - Automotive Market
  - Technology Overview
- Open Alliance SIG
- BroadR-Reach Testing challenges
- Tektronix BRR “One Box Solution”
  - Option BRR & Measurements Covered
  - Live Setup using Broadcom BCM89810
  - Fixture
  - Complete Solution from Tektronix
- Features and Benefits
- Live Demo



# BroadR-Reach & Automotive Market



# BroadR-Reach Application

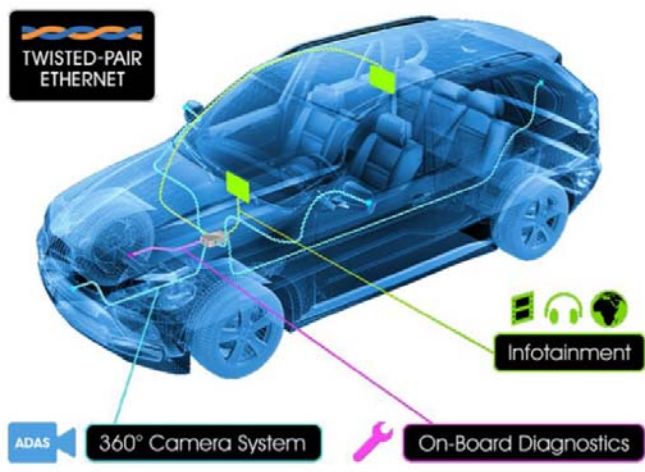

## Automotive Semiconductor Demand on the Rise

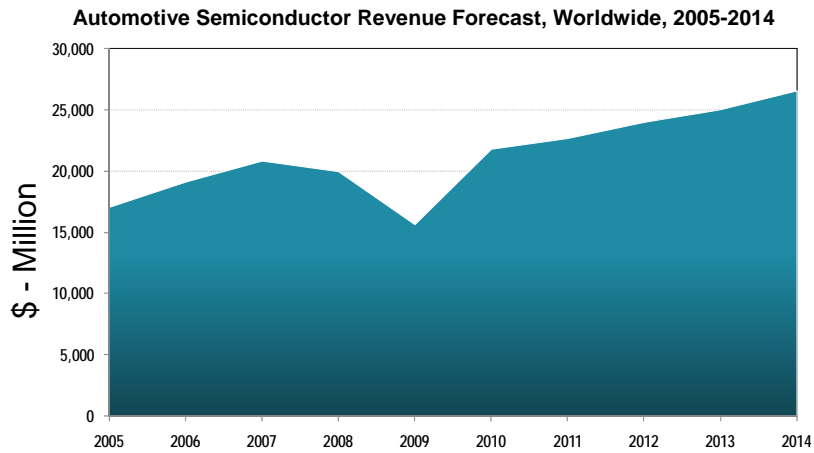

5 1/23/2014

Source: Gartner, Inc. - Automotive Semiconductors, Worldwide, 2009-2014; Feb. 11, 2011



## Industry Trends & Challenges

- **Substantial increase in prevalence of in-vehicle electronics**
  - Nearly doubled over the last decade\*
- **Growing in volume and complexity**
  - Substantial increase in cameras, diagnostics, ADAS, infotainment, etc.
  - In-dash display consoles evolving to computerized nerve centers
- **Bandwidth challenges**
  - More data requires higher transmission rates
- **Compatibility and need for open architecture**
  - In-vehicle networks should be scalable, support multiple systems and devices
  - Networks need ability to converge
  - Auto makers demand open architecture
- **Cable limitations**
  - Auto makers seeking less costly forms of wiring
- **Industry standards**
  - In-vehicle technologies must meet strict regulations
  - Reliability, temperatures, minimal power consumption

\*Source: ABI Semiconductor Forecast

6 1/23/2014



# BroadR-Reach Technology Overview

## Technology Overview

- BroadR-Reach™ is a Broadcom® technology used over wide range of cables including 1-pair UTP cable.
- BroadR-Reach Physical Layer (PHY) (IEEE Standard 802.3ab Clause 22).
- For Automotive applications, each copper port supports one twisted pair line connection.
- BroadR-Reach provides data rates of 100Mbps at the MAC interface over a single pair cable.
- This specification, with reference to IEEE Standard 802.3ab , defines PCS & PMA sub-layer.
- Together, the PCS and the PMA sub-layers comprise a BroadR-Reach Physical layer (PHY).

## BroadR-Reach Preview

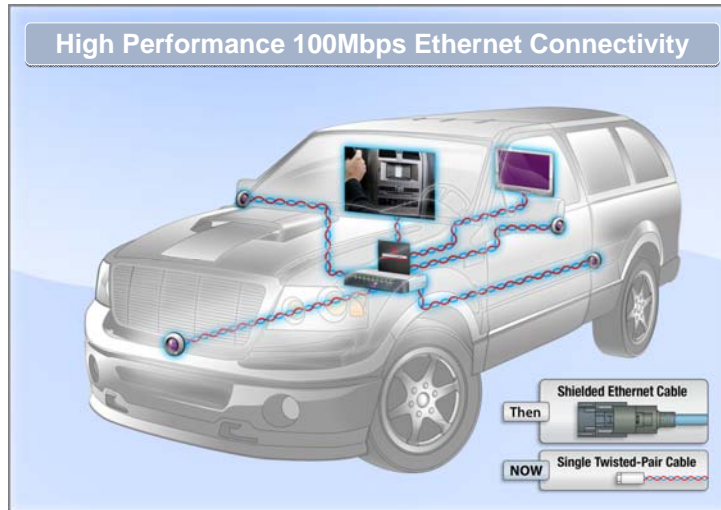

**Reduces connectivity cost up to 80%\***

Source Broadcom

\* Source: Based on current market prices for unshielded single twisted pair Flex Ray cables/connectors and shielded LVDS cables/connectors.

9 1/23/2014



## 100 Mbps Over Unshielded Single Twisted Pair Cable

100 Mbps symmetrical operation using standard Ethernet PHY components

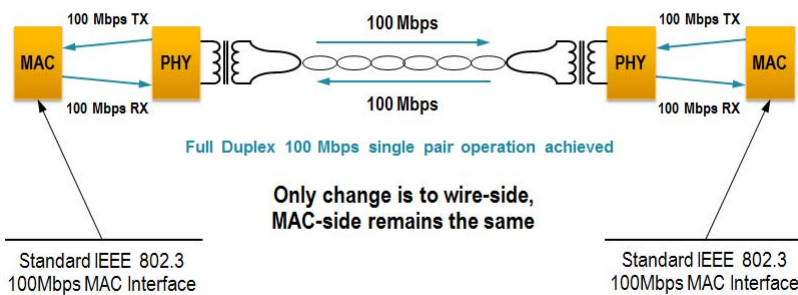



Source: Broadcom

10 1/23/2014

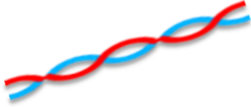
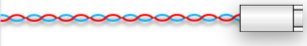

## Connectivity Comparison At-a-Glance

	Cable	Connector (2 ends, on-board and cable)
LVDS		
BroadR-Reach		

Reduces connectivity costs up to 80%\*

Reduces cabling weight up to 30%\*

\* Source : Broadcom Presentation

11 1/23/2014

**Tektronix**

## OPEN ALLIANCE SIG



12 1/23/2014

**Tektronix**

# BroadR-Reach Testing Challenges

## Measurement List

CTS Section	Measuremnts	Test Mode	Fixture Section	Limit		
				Min	Max	Units
<b>5.4 Transmitter Electrical Specifications</b>						
5.4.1	Transmitter Output Droop	Test mode 1	TC2		45	%
5.4.2	Transmitter Distortion with disturbing signal	Test mode 4	TC5		15	mV
5.4.2	Transmitter Distortion without disturbing signal	Test mode 4	TC2		15	mV
5.4.3	Transmitter Timing Jitter - Master	Test mode 2	TC2		50	ps
5.4.3	Transmitter Timing Jitter - Slave	TX_TCLK	TC2		150	ps
5.4.4	Transmitter Power Spectral Density (PSD)	Test mode 5	TC2		-	Mask Hits
5.4.5	Transmit Clock Frequency	Test mode 2	TC2	66.66	66.67	MHz
<b>8.0 Link segment characteristics</b>						
8.2.2	Return Loss	Test mode 5	TC1		-	Mask Hits

## Transmitter Output Droop – 5.4.1

- Test mode 1 signal averaged over time is given as input for this measurement.
- Positive Droop is determined for every positive pulse and averaged positive droop is reported as result. Similarly negative droop is calculated.

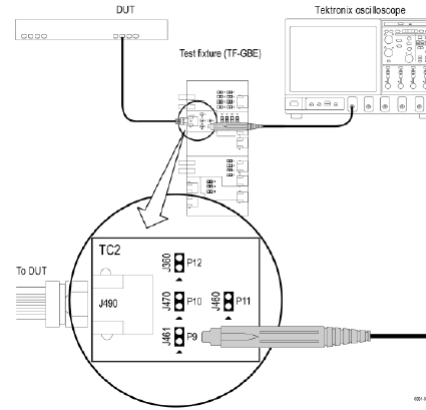
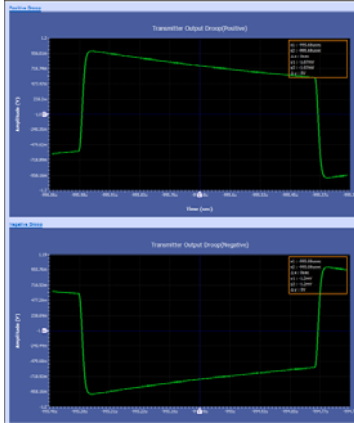

- Positive Droop Result = Average (PD1, PD2...PDn)
- Negative Droop Result = Average (ND1, ND2... NDn);

15 1/23/2014



## Transmitter Distortion – 5.4.2

- Test mode 4 signal averaged over time is given as input for this measurement
- Test mode 4 signal contains PAM3 modulated pattern which is repeated every 2047 bits. Within 2047 bits, there is a unique pattern which will give widest positive pulse width. This pulse can be found between bit 1029 and 1062. We can trigger on this pattern and use this information for computing clock unit interval and for frame

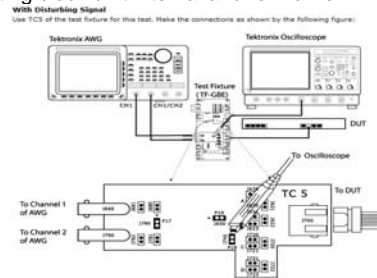
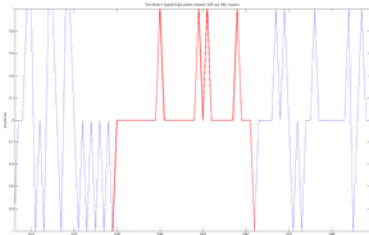

- Internally we remove any DC offset, filter the signal using an HPF with cut off frequency of 1.067 MHz and then filter the signal using an LPF(noise elimination) with cut off frequency - 150 MHz
- We use Matlab code given in specification for computing peak distortion. We compute peak distortions at 10 different phase offsets (0 to 1UI in steps of 0.1UI).
- If we get 6 peak distortions less than 15 mV, then test is pass else test fails.

16 1/23/2014





## Transmitter Timing Jitter – 5.4.3

- Master Jitter:
  - Test mode 2 signal is given as input to this measurement
  - Time Interval Error between edges of test mode 2 signal and un-jittered reference is determined.
  - RMS value of the time interval error is reported as master jitter (J\_TXOUT)
- Slave Jitter:
  - Slave TX\_TCLK is given as input to this measurement. DUT shall be in normal mode connected to link partner (LP operating as master).
  - Time Interval Error between edges of slave TX\_TCLK and un-jittered reference is determined.
  - RMS value of the time interval error is reported as slave jitter

Without Disturbing Signal  
Use TC2 of the test fixture for this test. Make the connections as shown by the following figure:

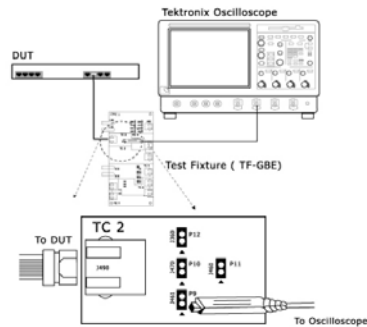

17 1/23/2014

Tektronix

## Transmitter Power Spectral Density – 5.4.4

- Test mode 5 signal is given as input to this measurement
- Spectrum of the input signal is computed using built in scope MATH functions. Post processing is done on spectrum to arrive at the PSD.
- Computed PSD is compared with specification - Lower and Upper masks
- Enables one box compliance testing, no need to switch between Real Time Oscilloscope and spectrum analyzer.
- Proven Method – 10GBASE-T, MIPI M-PHY

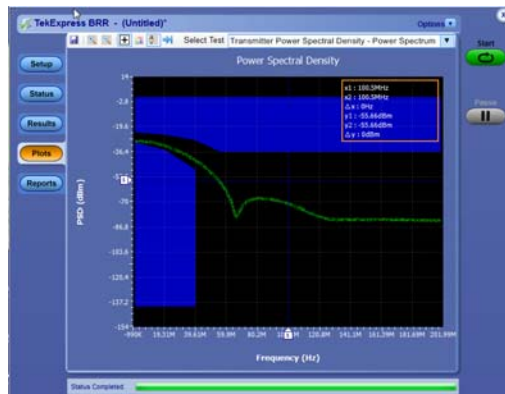

18 1/23/2014

Tektronix

## Transmit Clock Frequency – 5.4.5

- Test mode 2 signal is given as input to this measurement
- Considering “x” as “edge numbers” and “y” as “edge positions”, a linear least square fitting of a straight line is made and the resulting slope is reported as unit interval.
- Reciprocal of unit interval gives the transmit clock frequency

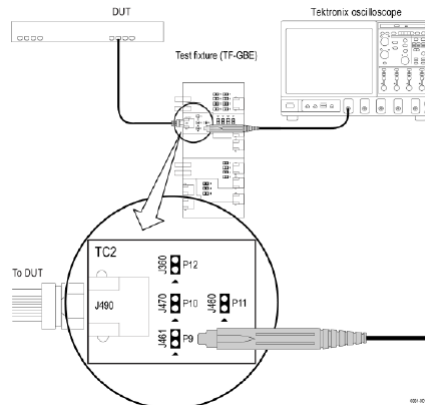

## MDI Return Loss – 7.1.3

- Incident and reflected waveforms are acquired and return loss is computed as part of post processing analysis.
- Waveform generator generates a differential test signal. Test fixture presents the differential signal to various loads – DUT, short, open and a balanced load.
- Oscilloscope acquires the differential signal during each loading conditions and then computes the error correction parameter using signals received with short, load and open conditions.
- Correction parameter tends to offset signal acquisition errors within measurements made during DUT load condition.
- No need of network analyzer for performing return loss measurement. Hence there is a reduction in overall cost of BroadR-Reach test setup.

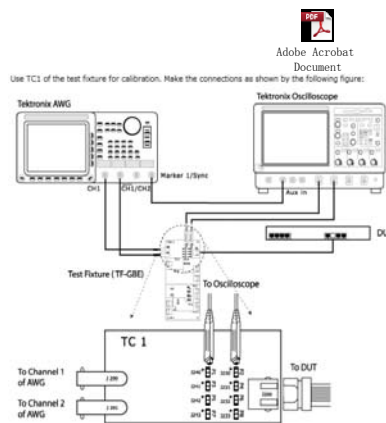

# Tektronix BRR – “One-Box-Solution”

21 1/23/2014



## Option BRR

The screenshot displays the TekExpress BRR software interface. On the left, a navigation pane shows steps: 1. Setup, 2. Test Selection, 3. Acquisition, 4. Configuration, and 5. Reports. The 'Test Selection' step is active, showing a list of test items for 'BRR: BroadR-Reach Physical Layer Transceiver Specification v1.2'. The 'Test Description' area notes: 'To verify that the transmitter output level does not drop more than the maximum specified amount.' On the right, a 'TekExpress BroadR-Reach Transmitter Test Report' is shown. It includes a 'Setup Information' table, a 'Test Name Summary Table', and detailed test results for 'Transmitter Clock Frequency' and 'Transmitter Timing Jitter - Master Jitter'.

Item	Value	Item	Value
TEST ID	027201	TekExpress BroadR-Reach	1.0.0.02
Pre-Recorded Mode	False	Framework Version	1.0.0.01
Overall Execution Time	0:10:00	Scope Model	DPO714C
Overall Analysis Time	0:09:46	Framework Version	8.0.1 (Build 1)
Overall Test Result	Pass		

Test Name	Result
Transmitter Clock Frequency	Pass
Transmitter Timing Jitter - Master Jitter	Pass
Transmitter Timing Jitter - Slave Jitter	Pass
Transmitter Output Power	Pass
Transmitter Power Spectral Density	Pass
Transmitter Distortion	Pass

Measurement Details	Measured Value	Units	Test Result	Margins	Low Limit	High Limit
Transmitter Clock	68.6682	MHz	Pass	L: -0.2049, H: 0.0019	68.6631	68.6700
COMMENTS: Number of user intervals: 41567						

Measurement Details	Measured Value	Units	Test Result	Margins	Low Limit	High Limit
Transmitter Timing Jitter - Master Jitter	42.61	ps	Pass	7.75	N/A	50
COMMENTS: Number of Edges: 50001						

22 1/23/2014



- Operates on Tektronix 5K, 7K & 70K Scopes(WIN7 scopes only)
- Automate setup & quickly generate reports
- Meets Compliance needs of BroadR-Reach

## Connection Diagram

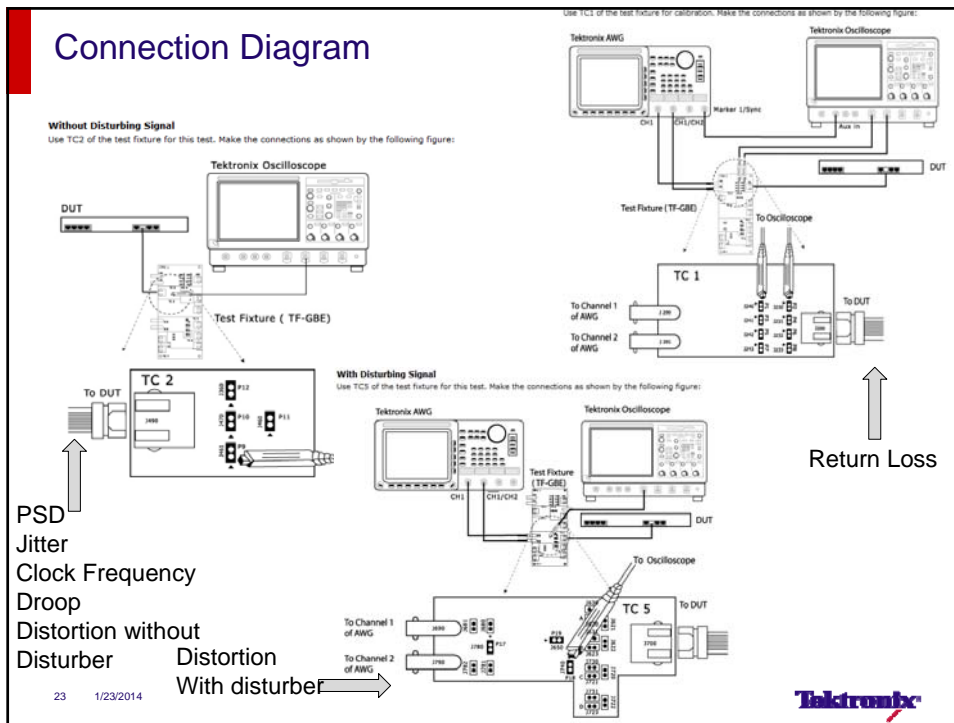

## Fixture

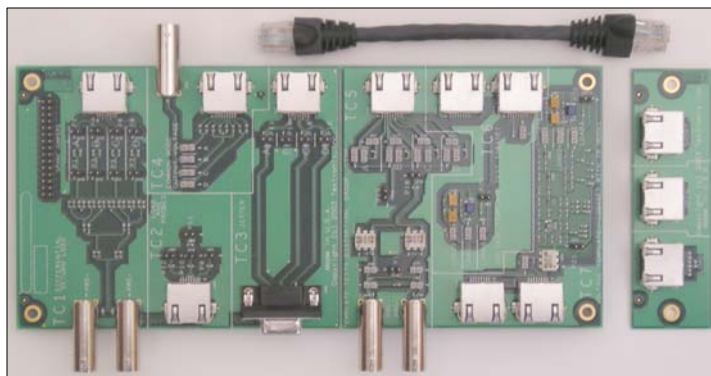

TF-GBE-BTP -- 1000/100/10BaseT Basic Test Package  
(consists of test fixture PCB set and RJ45 interconnect cable)

## BRR Complete Solution

Platform	All 5K, 7K, 70K(WIN 7 only)
Software Options	Option BRR
Probing	For Return Loss - 2 # P6248, P6247(Any One Model)*
	For all Other Measurements - 1 # P6247, P6248, P6330, TDP1500, TDP3500, P7330, P7350(Any Model)
Signal Source	AFG3102, AFG3252, AWG5000, AWG7000
Fixture	TF-GBE-BTP -- Test Package (consists of test fixture PCB set and RJ45 interconnect cable)
Other Accessories	1. 2 Pair SMA cables 2. 3# SMA-BNC Adapter

\*P6248/P6247 when used on 5K/7K scopes require TPA-BNC adapter

### Mapping Technology to Oscilloscope Bandwidth Requirements

- Max Data Rate for PAM3 signal – 66.66 MHz
- $66.66 / 2 * 5 = 165$  MHz
- Any model of 5K, 7K and 70K can be used for Option BRR

## Features and Benefits

Features	Benefits
"One-Box-Solution" – Power Spectral Density	"One Box solution" BRR uses scope for performing PSD. When performing BroadR-Reach PHY layer testing Engineers can use scope rather than using Spectrum Analyzer. BRR provides simplified setup and cost effective solution.
"One-Box-Solution" – Return Loss Measurement	"One Box solution" BRR uses scope for performing Return Loss. When performing BroadR-Reach PHY layer testing customers can use scope rather than using a VNA. BRR provides simplified setup and cost effective solution.
Disturber Feature for performing Distortion measurement	Tektronix BRR solution including fixture provides a mechanism to add disturbing signal which is mandatory for performing Distortion measurement. Distortion measurement is one of the most important measurement recommended by the specification
Reduces Testing Time	Tektronix Automated BRR Compliance and Automation solution meets compliance needs of BroadR-Reach 1.2 specifications. Users can save up to 90% on testing time as compared to manual testing.
"One Stop Shop" - Test Fixture Availability	Engineers working on BroadR-Reach can turn to Tektronix for their complete PHY testing solution needs including fixtures and don't have to design their own fixtures
Scope Setup, Limits, and standard specific measurements	Simplifies test setup and eliminates human error resulting in more rapid compliance testing of BroadR-Reach designs along with reduced human error due to instrument setup.

27 1/23/2014



## Live Setup using Broadcom BCM89810

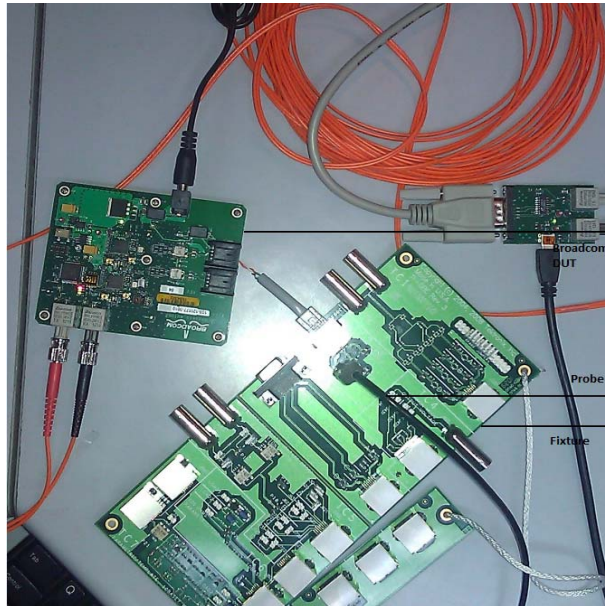

28 1/23/2014



## Tektronix Ethernet Solution – Information

- Tektronix has strong portfolio of products and solution in Ethernet Space – RT Scope, Sampling scope, BERTScope and Optametra products
- TDSET3 – Since 2003 with, ET3 is widely used solution across industry
- XGbT –10GBASE-T Compliance solution is the only “One Box” solution available in the market
- SFP-TX & SFP-WDP provides comprehensive solution for SFP+ & QSFP+, Tektronix is first to market
- 10GBASE-KR - 802.3ap™-2007 – We now have a Compliance, Debug and Decode Solution
- FC-16G – Fiber Channel 16G Compliance and Debug solution available on RT Scopes
- 802.3az – Energy Efficient Ethernet –Tektronix was the first T&M company to develop a solution in this space
- 10GBASE-KR and SFP+ RX MOI are available on BERT Scope
- BroadR-Reach Solution Available
- Intend to work on 40GBASE-CR4 and SR4

1/23/2014

29





1/23/2014

30

