

# 10Gbit/s XFP Transceiver 1310 nm (TRX10GDP0x01)

## Features

- Fully compliant to XFP MSA Rev. 4.5
- Multi-Protocol in the range of 9.9....10.7Gb/s for SONET/SDH, Ethernet and Fibre Channel Applications
- Compatible with 10.7Gbit/s and 11.3Gbit/s operation for FEC functionality
- Transmission distance up to 10km over single mode fiber
- Low power consumption <1.5W (typ.)
- Wide operating temperature range: 0°C to +70°C
- Laser Class 1 compliant
- Uncooled 1310nm Laser
- LC duplex connector
- Hot pluggable 30pin connector
- XFI electrical interface, AC-coupled
- Compliant with the EU RoHS 6 environmental requirements



## General Description and Applications

The TRX10GDP0x01 is a multi-purpose serial optical transceiver module for 10Gbit/s applications. The standard compliant transceiver is ideally suited for datacom, storage area network (SAN / NAS) and SONET/SDH applications. Designed for long reach the transceiver module comprises a transmitter with an uncooled laser and a receiver with a PIN photodiode. The transceiver operates within a wide temperature range of 0°C to +70°C and offers optimum heat dissipation and excellent electromagnetic shielding thus enabling high port densities for 10GbE systems. A 30 pin electrical connector and a duplex LC connector optical interface assure the MSA compliant connectivity of the solid metal XFP package.

Standard	Description	Nominal Baud Rate	Unit
SDH	ITU-T G.691	9.95	GBd
SDH	ITU G.709 (OUT-2) OC-192 with FEC	10.71	GBd
SONET	GR-253-Core	9.95	GBd
IEEE 802.3ae	10GBASE-LR	10.31	GBd
10G Fibre Channel	1200-SM-LL-L	10.52	GBd

## Electrical Characteristics

### Absolute Maximum Ratings

Rating	Conditions	Symbol	Min	Max	Units
Storage Ambient Temperature Range		$\vartheta_{stg}$	-40	+85	°C
Powered Case Temperature Range		$\vartheta_c$	0	+75	°C
Operating Relative Humidity		RH	8	80	%
Supply Voltage Range @ 5.0V		$V_{CC5}$	0.5	6.0	V
Supply Voltage Range @ 3.3V		$V_{CC3}$	0.5	3.6	V
Open Drain VCC Level		$V_{OD}$		3.6	V
Static Discharge Voltage on XFI High Speed Pins	HBM human body model per JEDEC JESD22-A114-B			500	V
Static Discharge Voltage excluding XFI High Speed Pins	HBM human body model			2,000	V
Static Discharge Voltage on XFP Module	EN61000-4-2 Criterion B: Air Discharge Direct Contact discharge			15,000 8,000	V V

Any stress beyond the maximum ratings can result in permanent damage. The device specifications are guaranteed only under the recommended operating conditions.

### Recommended Operating Conditions

Parameter	Conditions	Symbol	Min	Typ	Max	Units
Operating Case Temperature Range		$\vartheta_{Case}$	0		+70	°C
Transceiver total Power Consumption		$P_{TOT}$	1.15	1.41	1.78	W
Power Supply Voltage @ 5.0V		$V_{CC5}$	4.75	5.00	5.25	V
Power Supply Voltage @ 3.3V		$V_{CC3}$	3.135	3.300	3.465	V
Supply Current	@ $V_{CC5}$	$I_{VCC5}$	0.5	1	4	mA
Supply Current	@ $V_{CC3}$	$I_{VCC3}$	379	432	516	mA

### High Speed Line Characteristics

Parameter	Conditions	Symbol	Min	Typ	Max	Units
Baud Rate nominal	As defined by related standard		9.95		11.3	Gbd
Baud Rate Tolerance			-100		+100	ppm

## High Speed Line Output - DC Characteristics

Parameter	Conditions	Symbol	Min	Typ	Max	Units
Single Ended Output Impedance		Z <sub>SE</sub>	40	50	60	Ω
Differential Output Impedance		Z <sub>OD</sub>	80	100	120	Ω

## High Speed Line Output - AC Characteristics

Parameter	Conditions	Symbol	Min	Typ	Max	Units
Differential Output Amplitude		V <sub>OSPP</sub>	340		850	mV
Output Common Mode		V <sub>CM</sub>	0		3.6	V
Transition Time Low to High		t <sub>r</sub>	24			ps
Transition Time High to Low		t <sub>f</sub>	24			ps
Differential Output Return Loss	0.05 – 0.1GHz 0.1 – 5.5GHz 5.5 – 12GHz		20 8 see 1)			dB dB
Common Mode Output Return Loss <sup>2)</sup>	0.1 – 15GHz	SCC 22	3			dB
Total Peak-to-Peak Jitter		D <sub>j</sub>			0.34	UI
Output AC Common Mode Voltage					15	mV (RMS)

1) SDD22(dB) = 8 - 20.66 log<sub>10</sub>(f15.5) with f in GHz

2) Common mode reference impedance is 25Ω. Common mode return loss helps absorb reflection and noise improving EMI.

## High Speed Line Input - DC Characteristics

Parameter	Conditions	Symbol	Min	Typ	Max	Units
Differential Output Impedance		R <sub>IND</sub>	80	100	120	Ω
Input AC Common Mode Input Voltage			0		25	mV (RMS)
Source to Sink DC Potential Difference		V <sub>CM</sub>	0		3.6	V

## High Speed Line Input - AC Characteristics

Parameter	Conditions	Symbol	Min	Typ	Max	Units
Differential Input Voltage Swing		V <sub>ID</sub>	120		820	mV
Differential Return Loss	0.05 – 0.1GHz 0.1 – 5.5GHz 5.5 – 12GHz	SDD11	20 8 see 1)			dB
Common Mode Return Loss	0.1 – 15GHz	SCC11	3			dB
Total Jitter		T <sub>j</sub>			0.61	UI

1) SDD11(dB) = 8 - 20.66 log<sub>10</sub>(f15.5) with f in GHz



## Optical Characteristics

### General Parameters

Parameter	Conditions	Symbol	Min	Typ	Max	Units
Operating Range		$l_{OP}$			10	km
Nominal Signalling Speed	Depending on used standard and provided reference clock	$f_{OPT}$	9.95		11.3	GBd
Speed Variation from Nominal Speed		$\Delta f_{OPT}$	-100		+100	ppm

### Optical Transmitter

Parameter	Conditions	Symbol	Min	Typ	Max	Units
Nominal Wavelength		$\lambda_{TRP}$	1290	1310	1330	nm
Spectral Width	-20dB down	$\Delta\lambda$	0.07	0.25	0.49	nm
Side Mode Suppression Ratio		SMSR	30	46	63	dB
Optical Output Power		$P_{out}$	-6.0	-3.5	-1.83	dBm
Extinction Ratio	OC-192, SDH	ER	6	7.1	8.5	dB
Extinction Ratio	10GBase-LR		5	5.8	7.5	dB
Optical Modulation Amplitude		OMA	302	596	1000	$\mu$ W
Laser Turn OFF Time	after TX_DIS goes to low		80	95	110	$\mu$ s
Relative Intensity Noise		RIN			-125	dB/Hz

### Optical Receiver

Parameter	Conditions	Symbol	Min	Typ	Max	Units
Center Wavelength		$\lambda_C$	1290	1310	1330	nm
Average Received Power		$P_{IN}$	-15		0.5	dBm
Receiver Sensitivity (OMA)	OC-192, SDH, $\lambda=1310/1550$ nm @modulation penalty 1dB	$P_{IN}$	-18.8	-17.5	-15	dBm
Receiver Sensitivity (OMA)	10GBase-LR, BER $10^{-12}$ @ $2^{31}-1$	$P_{IN}$	-18.8	-17.5	-15	dBm
Stressed Receiver Sensitivity (OMA)	10GBase-LR	$P_{IN}$	-12.2			dBm
Saturation Input Power		$P_{SAT}$			1	dBm
LOS Detect Asserted		$P_{LOS}$	-30	-21	-18	dBm
Optical Return Loss		ORL			-14	dB
Receiver Reflectance			-27			dB

## Hostboard Connector Pinout

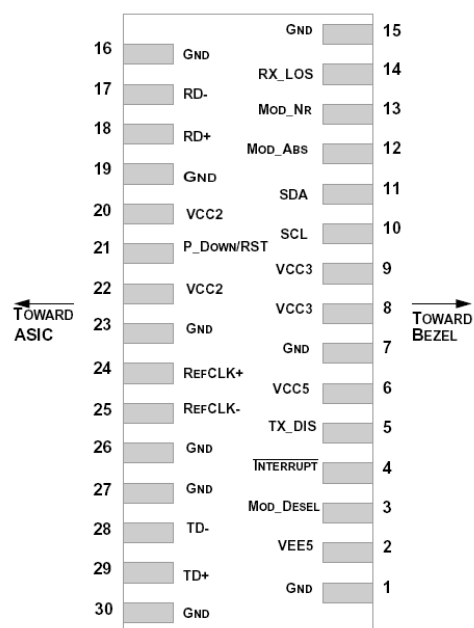

Top View



## Electrical Pin Definition

<b>PIN</b>	<b>Logic</b>	<b>Symbol</b>	<b>Name / Description</b>	<b>Note</b>
1		GND	Module Ground	1
2		VEE5	Optional -5.2V Power Supply	
3	LVTTTL-I	Mod_DeSel	Mode De-select; When held low allows module to respond to 2-wire serial interface commands	
4	LVTTTL-O	Interrupt	Interrupt (inverted); Indicates presence of an important condition which can be read over the 2-wire serial interface	2
5	LVTTTL-I	TX_DS	Transmitter Disable; Turns off transmitter laser output	
6		VCC5	+5V Power Supply	
7		GND	Module Ground	1
8		VCC3	+3.3V Power Supply	
9		VCC3	+3.3V Power Supply	
10	LVTTTL-I/O	SCL	2-Wire Serial Interface Clock	2
11	LVTTTL-I/O	SDA	2-Wire Serial Interface Data Line	2
12	LVTTTL-O	Mod_Abs	Indicates Module is not present. Grounded in the module	2
13	LVTTTL-O	Mod_NR	Module Not Ready; Indicating module operational fault	2
14	LVTTTL-O	RX_LOS	Receiver Loss Of Signal Indicator	2
15		GND	Module Ground	1
16		GND	Module Ground	1
17	CML-O	RD-	Receiver Inverted Data Output	
18	CML-O	RD+	Receiver Non-Inverted Data Output	
19		GND	Module Ground	1
20		VCC2	+1.8V Power Supply (not required by TRX10GDP)	
21	LVTTTL-O	P_Down/RST	Power down; When high, requires the module to limit power consumption to 1.5W or below. 2-Wire serial interface must be functional in the low power mode. Reset; The falling edge initiates a complete reset of the module including the 2-wire serial interface, equivalent to a power cycle.	
22		VCC2	+1.8V Power Supply (not required by TRX10GDP)	
23		GND	Module Ground	1
24	PECL-I	RefCLK+	Reference Clock Non-Inverted Input, AC coupled on the host board	
25	PECL-I	RefCLK-	Reference Clock Inverted Input, AC coupled on the host board	
26		GND	Module Ground	1
27		GND	Module Ground	1
28	CML-I	TD-	Transmitter Inverted Data Input	
29	CML-I	TD+	Transmitter Non-Inverted Data Input	
30		GND	Module Ground	1

- 1) Module ground pins GND are isolated from the module case and chassis ground within the module.
- 2) Shall be pulled up with 4.7K $\Omega$  -10K $\Omega$  to a voltage between 3.15V and 3.45V on the host board.

## 2-wire Management Interface

### Memory specification

Parameter	Symbol	Min.	Max.	Unit	Conditions
Complete Single or Sequential Write	tWR		16	ms	Complete (up to) 4 Byte Write
Endurance (Write Cycles)		50 k	> 200 k	cycles	

### Single Byte Writable Memory Blocks

Byte Address	Volatile or NV	Description
110	V	General Control Bits
118	V	Packet Error Checking Control
127	V	Table Select Byte

### Multiple Byte Writable Memory Blocks

Byte Address	Volatile or NV	Description
88-93	V	Interrupt Masking Bits
119-122	V	Password Change Entry
123-126	V	Password Entry
128-255	NV	Table 02h – Customer Writable

### Memory overview

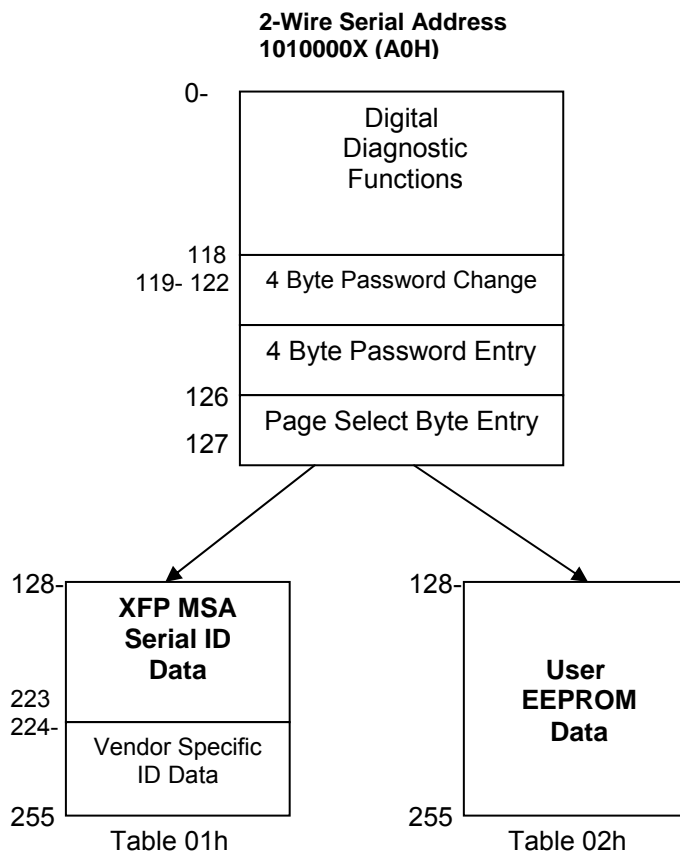

The Transceiver module provides a lower memory (byte address 0-127) as well as table 01h and table 02h. The device address of module is always A0h.



## Lower Memory map

Byte address	Default value (hex)	Description
0	06	Identifier
1	00	Signal Conditioner Control
2-57	See table below	Threshold Values used for Alarm and Warning Flags
58-59	00	Optional VPS Control Registers (no function)
60-69	00	Reserved
70-71	00	BER Reporting (no function)
72-75	00	Wavelength Control Registers (no function)
76-79	00	FEC control Registers (no function)
80-95	-	Flags and Interrupt Control
96-109	-	A/D readout
110-111	-	General Control/Status bits
112-117	00	Reserved
118	-	Serial Interface Read/Write Error Checking
119-122	-	Password Change Entry Area
123-126	-	Password Entry Area
127	01	Page Select Byte

## Threshold Values used for Alarm and Warning Flags

Byte address	Default value (hex)	Name	Description
02-03	4B, 00	Temp High Alarm	75°C - MSB at low address
04-05	FB, 00	Temp Low Alarm	-5°C - MSB at low address
06-07	46, 00	Temp High Warning	70°C - MSB at low address
08-09	00, 00	Temp Low Warning	0°C - MSB at low address
10-17	88, B8	Reserved VCC3 High Alarm	3.5V – MSB at low address
12-13	79, 18	Reserved VCC3 Low Alarm	3.1V – MSB at low address
14-15	86, C4	Reserved VCC3 High Warning	3.45V – MSB at low address
16-17	7B, 0C	Reserved VCC3 Low Warning	3.15V – MSB at low address
18-19	EA, 60	Bias High Alarm	60mA - MSB at low address
20-21	27, 10	Bias Low Alarm	10mA - MSB at low address
22-23	D6, D8	Bias High Warning	55mA - MSB at low address
24-25	3A, 98	Bias Low Warning	15mA - MSB at low address
26-27	2E, E0	TX Power High Alarm	1200µW - MSB at low address
28-29	03, E8	TX Power Low Alarm	100µW - MSB at low address
30-31	27, 10	TX Power High Warning	1000µW - MSB at low address
32-33	05, DC	TX Power Low Warning	150µW - MSB at low address
34-35	27, 10	RX Power High Alarm	1000µW - MSB at low address
36-37	00, 1E	RX Power Low Alarm	3µW - MSB at low address
38-39	23, 28	RX Power High Warning	900µW - MSB at low address
40-41	00, 5A	RX Power Low Warning	9µW - MSB at low address
42-43	D2, F0	AUX 1 High Alarm	5.4V - MSB at low address
44-45	AF, C8	AUX 1 Low Alarm	4.5V - MSB at low address
46-47	CD, 14	AUX 1 High Warning	5.25V - MSB at low address
48-49	B9, 8C	AUX 1 Low Warning	4.75V - MSB at low address
50-51	17, 70	AUX 2 High Alarm	No function
52-53	00, C8	AUX 2 Low Alarm	No function
54-55	15, 7C	AUX 2 High Warning	No function

56-57	01, F4	AUX 2 Low Warning	No function
-------	--------	-------------------	-------------

### Flags and Interrupt Control

Byte address	Bit	Description
80	7	Latched high Temperature alarm
80	6	Latched low Temperature alarm
80	5	Reserved
80	4	Reserved
80	3	Latched high TX Bias alarm
80	2	Latched low TX Bias alarm
80	1	Latched high TX Power alarm
80	0	Latched low TX Power alarm
81	7	Latched high RX Power alarm
81	6	Latched low RX Power alarm
81	5	Latched high AUX1 monitor alarm
81	4	Latched low AUX1 monitor alarm
81	3	Latched high AUX2 monitor alarm
81	2	Latched low AUX2 monitor alarm
81	1	Reserved
81	0	Reserved
82	7	Latched high Temperature warning
82	6	Latched low Temperature warning
82	5	Reserved
82	4	Reserved
82	3	Latched high TX Bias warning
82	2	Latched low TX Bias warning
82	1	Latched high TX Power warning
82	0	Latched low TX Power warning
83	7	Latched high RX Power warning
83	6	Latched low RX Power warning
83	5	Latched high AUX1 monitor warning
83	4	Latched low AUX1 monitor warning
83	3	Latched high AUX2 monitor warning
83	2	Latched low AUX2 monitor warning
83	1	Reserved
83	0	Reserved
84	7	Latched TX_NR Status
84	6	Latched Laser Fault condition
84	5	Latched TX CDR Loss of Lock
84	4	Latched RX_NR Status
84	3	Latched mirror of RX_LOS pin (Receiver loss of optical signal)
84	2	Latched RX CDR Loss of Lock
84	1	Latched Mirror of MOD_NR pin
84	0	Latched Reset Complete Flag
85	7	Latched APD Supply Fault
85	6	Latched TEC Fault
85	5	Latched Wavelength Unlocked Condition
85	4	Reserved
85	3	Reserved
85	2	Reserved

85	1	Reserved
85	0	Reserved
86	7	VCC5 High Alarm Flag
86	6	VCC5 Low Alarm Flag
86	5	VCC3 High Alarm Flag
86	4	VCC3 Low Alarm Flag
86	3	VCC2 High Alarm Flag
86	2	VCC2 Low Alarm Flag
86	1	Vee5 High Alarm Flag
86	0	Vee5 Low Alarm Flag
87	7	VCC5 High Warning Alarm Flag
87	6	VCC5 Low Warning Flag
87	5	VCC3 High Warning Flag
87	4	VCC3 Low Warning Flag
87	3	VCC2 High Warning Flag
87	2	VCC2 Low Warning Flag
87	1	Vee5 High Warning Flag
87	0	Vee5 Low Warning Flag

#### Masking of interrupts

Byte address	Bit	Description
88	7	Masking bit for high Temperature alarm
88	6	Masking bit for low Temperature alarm
88	5	Reserved
88	4	Reserved
88	3	Masking bit for high TX Bias alarm
88	2	Masking bit for low TX Bias alarm
88	1	Masking bit for high TX Power alarm
88	0	Masking bit for low TX Power alarm
89	7	Masking bit for high RX Power alarm
89	6	Masking bit for low RX Power alarm
89	5	Masking bit for high AUX1 monitor alarm
89	4	Masking bit for low AUX1 monitor alarm
89	3	Masking bit for high AUX2 monitor alarm
89	2	Masking bit for low AUX2 monitor alarm
89	1	Reserved
89	0	Reserved
90	7	Masking bit for high Temperature warning
90	6	Masking bit for low Temperature warning
90	5	Reserved
90	4	Reserved
90	3	Masking bit for high TX Bias warning
90	2	Masking bit for low TX Bias warning
90	1	Masking bit for high TX Power warning
90	0	Masking bit for low TX Power warning
91	7	Masking bit for high RX Power warning
91	6	Masking bit for low RX Power warning
91	5	Masking bit for high AUX1 monitor warning
91	4	Masking bit for low AUX1 monitor warning
91	3	Masking bit for high AUX2 monitor warning

91	2	Masking bit for low AUX2 monitor warning
91	1	Reserved
91	0	Reserved
92	7	Masking bit for TX_NR Status
92	6	Masking bit for Laser Fault condition
92	5	Masking bit for TX CDR Loss of Lock
92	4	Masking bit for RX_NR Status
92	3	Masking bit for mirror of RX_LOS pin
92	2	Masking bit for RX CDR Loss of Lock
92	1	Masking bit for Mirror of MOD_NR pin
92	0	Masking bit for Reset Complete Flag
93	7	Masking bit for APD Supply Fault
93	6	Masking bit for TEC Fault
93	5	Masking bit for Wavelength Unlocked Condition
93	4	Reserved
93	3	Reserved
93	2	Reserved
93	1	Reserved
93	0	Reserved
94	7	VCC5 High Alarm Flag
94	6	VCC5 Low Alarm Flag
94	5	VCC3 High Alarm Flag
94	4	VCC3 Low Alarm Flag
94	3	VCC2 High Alarm Flag
94	2	VCC2 Low Alarm Flag
94	1	Vee5 High Alarm Flag
94	0	Vee5 Low Alarm Flag
95	7	VCC5 High Warning Alarm Flag
95	6	VCC5 Low Warning Flag
95	5	VCC3 High Warning Flag
95	4	VCC3 Low Warning Flag
95	3	VCC2 High Warning Flag
95	2	VCC2 Low Warning Flag
95	1	Vee5 High Warning Flag
95	0	Vee5 Low Warning Flag

#### A/D readout<sup>1</sup>

Byte address	Description
96-97	Internally measured module temperature
98-99	Reserved – 3V3 monitoring
100-101	Internally measured TX Bias Current
102-103	Measured TX output power
104-105	Measured RX input power
106-107	Auxiliary measurement 1 defined in Byte 222 Page 01h – 5V
108-109	Auxiliary measurement 2 defined in Byte 222 Page 01h – not used

<sup>1</sup> MSB always at low address



### General Control/Status bits

Byte address	Bit	Description
110	7	TX Disable State Digital state of the TX Disable Input Pin.
110	6	Soft TX Disable Optional read/write bit that allows software disable of laser. Writing '1' disables laser. This bit is "OR"d with the hard TX_DISABLE pin value. Default power up value is 0.
110	5	MOD_NR State Digital state of the MOD_NR Pin.
110	4	P_Down State Digital state of the P_Down Pin.
110	3	Soft P_Down Optional read/write bit that allows the module to be placed in the power down mode. This is identical to the P_Down hardware pin function except that it does not initiate a system reset.
110	2	Interrupt Digital state of the Interrupt output pin.
110	1	RX_LOS Indicates Optical Loss of Signal (per relevant optical link standard).
110	0	Data_Not_Ready Indicates transceiver has achieved power up and A/D data is ready. Bit remains high until data is ready to be read at which time the device sets the bit low.
111	7	TX_NR State Identifies Not Ready condition as specific to the TX path
111	6	TX_Fault State Identifies Laser fault condition (Generated by laser safety system)
111	5	TX_CDR not Locked Identifies Loss of Lock in TX path CDR
111	4	RX_NR State Identifies Not Ready condition as specific to the TX path
111	3	RX_CDR not Locked Identifies Loss of Lock in RX path CDR
111	2	Reserved
111	1	Reserved
111	0	Reserved

### Serial Interface Read/Write Error Checking

Transceiver supports CRC-8 checking of every communication via I<sup>2</sup>C according XFP MSA Rev4.5. By default this functionality is disabled after reset.

Byte address	Bit	Description
118	1-7	Reserved
118	0	0 b = Disable Packet Error Checking 1 b = Enable Packet Error Checking

### Password change Entry Area

Bytes 119-122 are used for changing Host manufacture password of module. If correct old Host manufacture password is insert in bytes 123-126 the password can be changed by inserting new password in bytes 119-122. After inserting new password it is immediately valid.

### Password Entry Area

In Bytes 123-126 a Host manufacture password can be inserted. If password match with current valid password saved in EE-PROM of module (for change password see above), write access to table 02h is permitted.

Initial Host manufacture password is 00001011h.

### Page select byte

In byte 127 desired memory pages will be select. A page 00h is not supported and will guide to page 01h. All pages higher than 2 are also not supported and will jump to page 01h.



## Memory map table 01h

Byte address	Default value (hex)	Description
128	06	Identifier Type of serial transceiver (XFP)
129	50	Extended identifier of type of serial transceiver (Power level2, with CDR, no Ref-Clock required, no CLEI code in table 02h)
130	07	Connector Code for connector type (LC-type)
131-138	40, 40, 00, 00, 00, 00, 80, 00	Transceiver Code for electronic compatibility or optical compatibility (10GBASE-LR, 1200-SM-LL-L, I-64.1r)
139	F0	Encoding Code for serial encoding algorithm (64B/66B, 8B10B, SONET Scrambled, NRZ)
140	63	BR-Min Minimum bit rate, units of 100 MBits/s
141	6B	BR-Max Maximum bit rate, units of 100 MBits/s.
142	0A	Length(SMF)-km Link length supported for SMF fiber in km
143	00	Link length supported for EBW 50/125 $\mu$ m fiber, units of 2 m
144	00	Link length supported for 50/125 $\mu$ m fiber, units of 1 m
145	00	Link length supported for 62.5/125 $\mu$ m fiber, units of 1 m
146	00	Link length supported for copper, units of 1m
147	40	Device technology (Transmitter not tunable, PIN detector, Uncooled transmitter device, No wavelength control, 1310nm DFB)
148-163	"MERGEOPTICS GmbH"	Vendor name XFP vendor name (ASCII)
164	F0	CDR Rate Support (CDR support for 10.7, 10.5, 10.3, 9.95 Gb/s)
165-167	00, 0A, 0D	XFP vendor IEEE company ID (MergeOptics OUI)
168-183	"TRX10GDP0501 "	Part number provided by XFP vendor (ASCII)
184-185	"01"	Revision level for part number provided by vendor (ASCII)
186-187	66, 58	Nominal laser wavelength (Wavelength = value / 20 in nm) (1310nm)
188-189	0F, A0	Guaranteed range of laser wavelength (+/- value) from Nominal wavelength. (Wavelength Tol. = value/200 in nm) (20nm)
190	46	Maximum Case Temperature in Degrees C (70°C)
191	C1	Check code for Base ID Fields (addresses 120-190)
192-195	see table below	Power supply current requirements and max power dissipation
196-211	"ML????????? "	Serial number provided by vendor (ASCII)
212-219	"YYMMDDL"	Vendor's manufacturing date code (ASCII)
220	08	Indicates which type of diagnostic monitoring is implemented (if any) in the transceiver (Rx power measurement = average power)
221	60	Indicates which optional enhanced features are implemented (if any) in the transceiver (Optional Soft Tx_Disable, Optional Soft_P_down implemented)
222	60	Defines quantities reported by Aux. A/D channels (AUX1 = 5V)
223	-	Check code for the Extended ID Fields (addresses 192 to 222)
224-255	00	Vendor Specific EEPROM

**Power Supply Power supply current requirements and max power dissipation**

Byte address	Default value (hex)	Description
192	7D	Maximum Power Dissipation Max power is 8 bit value * 20 mW. (2.5W)
193	96	Maximum Total Power Dissipation in Power Down Mode Max Power is 8 bit value * 10 mW. (1.5W)
194	16	Bit 7-4 Maximum current required by +5V Supply. Max current is 4 bit value * 50 mA. [500 mA max] (50mA) Bit 3-0 Maximum current required by +3.3V Supply. Max current is 4 bit value * 100 mA. (600mA)
195	00	Bit 7-4 Maximum current required by +1.8V Supply Max current is 4 bit value * 100 mA. (0mA) Bit 3-0 Maximum current required by -5.2V Supply. Max current is 4 bit value * 50 mA. [500 mA max] (0mA)

**Memory map table 02h**

Byte address	Default value (hex)	Description
128 - 255	00	User EEPROM Data

## Electro Static Discharge (ESD)

The maximum electrostatic charge based on a human body model and the conditions as outlined below is:

<i>Parameter</i>	<i>Conditions</i>	<i>Symbol</i>	<i>Min</i>	<i>Typ</i>	<i>Max</i>	<i>Units</i>
On XFI High Speed Pins	JEDEC JESD22-A114-B				500	V
On XFI Pins excluding High Speed Pins	JEDEC JESD22-A114-B				2,000	V
On XFP Module	Air Discharge EN61000-4-2 criterion B				15,000	V
On XFP Module	Direct Contact Discharge EN61000-4-2 criterion B				8,000	V

## Thermal Management

The transceiver is designed for an operation within a case temperature range between 0 to +70°C at an altitude of < 3km. The user needs to guarantee per system design to not exceed this temperature range. It has to be considered that in case of use of multiple modules on a single hostboard that there is a temperature rise among the modules hosted side by side. Airflow direction and air speed needs to be chosen accordingly.

## Eye Safety

This laser based multimode transceiver is a Class 1 product. It complies with IEC 60825-1: 2007 and FDA performance standards for laser products (21 CFR 1040.10 and 1040.11) except for deviations pursuant to Laser Notice 50, dated June 24, 2007.

### CLASS 1 LASER PRODUCT

Caution: use of controls or adjustments or performance of procedures other than those specified herein may result in hazardous radiation.

*Note: All adjustments have been made at the factory prior to shipment of the devices. No maintenance or alteration to the device is required. Tampering with or modifying the performance of the device will result in voided product warranty. Failure to adhere to the above restrictions could result in a modification that is considered an act of "manufacturing", and will require, under law, recertification of the modified product with the U.S. Food and Drug Administration (ref. 21 CFR 1040.10 (i)).*

### Laser Emission Data

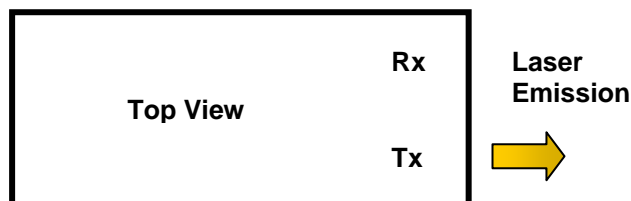

Wavelength	1310 nm
Maximum total output power (as defined by IEC: 7 mm aperture at 14 mm distance)	15.6 mW / 11.9 dBm
Beam divergence (full angle) / NA (half angle)	11° / 0.1 rad

### Required Labeling

#### FDA

Compliant to 21 CFR  
1040.10 and 1040.11

#### IEC

Class 1 Laser Product

## Ordering Information

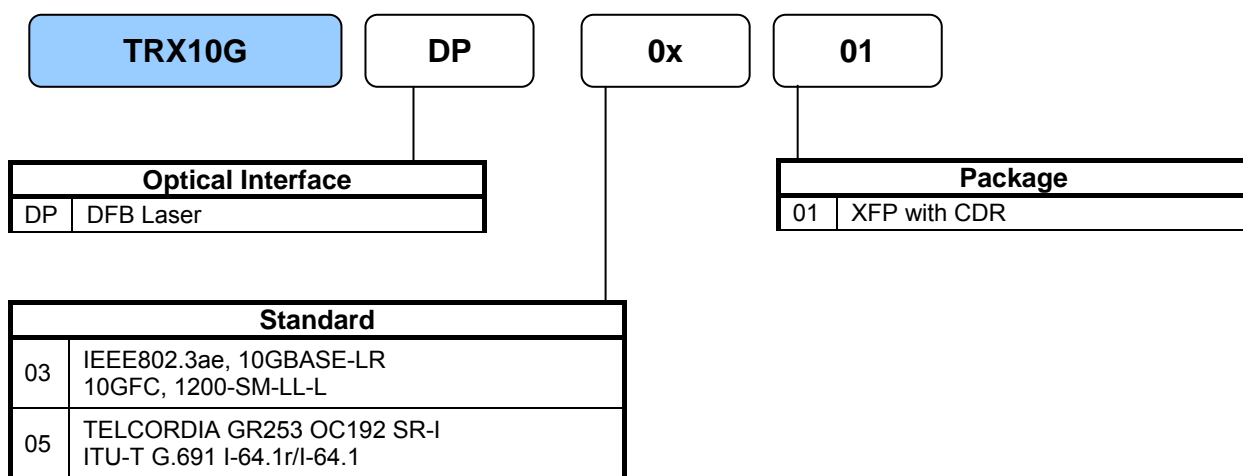

For more information on our products, please email us at [info@mergeoptics.com](mailto:info@mergeoptics.com) or visit our website [www.mergeoptics.com](http://www.mergeoptics.com)