

## ST STHV748 高性能超声波脉冲控制方案

ST 公司的 STHV748 是 4 路 5 级 $\pm 90\text{V}$ , 2 A 高性能高速超声波脉冲控制器, 输出电压从 0V 到 90V, 工作频率高达 20MHz, 抖动低至 20ps, 具有抗交叉导通功能和低 2 次谐波失真特性, STHV748 应用在医疗超声波图像, 脉冲发生器, NDT 超声波发送和压电传感器驱动器. 本文介绍 STHV748 主要特性, 方框图和典型应用电路.

World's Most Integrated High-Performance Ultrasound Pulse Controller

STHV748: 5-level,  $\pm 90\text{ V}$ , 2 A high-speed pulser with four independent channels

This monolithic, high-voltage, high-speed pulser generator features four independent channels. It is designed for medical ultrasound applications, but can also be used for other piezoelectric, capacitive or MEMS transducers. The device comprises a controller logic interface circuit, level translators, MOSFET gate drivers, noise blocking diodes and high-power P-channel and N-channel MOSFETs as output stage for each channel, clamping-to-ground circuitry, anti-leakage, antimemory effect block, thermal sensor and HV receiver switch (HVR\_SW) which guarantees a strong decoupling during transmission phase. Moreover the STHV748 includes self biasing and thermal shutdown blocks.

Each channel can support up to five active output levels with two half bridges. The output stage of each channel is able to provide  $\pm 2\text{ A}$  peak output current. In order to reduce power dissipation during continuous wave mode, the peak current is limited to 0.6 A.

STHV748 主要特性:

- High-density ultrasound transmitter
- 0 to  $\pm 90\text{ V}$  output voltage
- Up to 20 MHz operating frequency
- Low-power, high-voltage drivers
- 2 independently supplied half bridges for each channel in pulse wave (PW) mode
- 5-level output waveform
- $\pm 2\text{ A}$  source and sink current

- Down to 20 ps jitter
- Anti-cross conduction function
- Low 2nd harmonic distortion
- Fine-tuning on propagation delay
- Fully integrated clamping-to-ground function
- 6  $\Omega$  synchronous active clamp
- Anti-leakage on output node
- Dedicated half bridge for continuous wave (CW) mode on each
- Down to 0.1 W power consumption
- $\pm 0.6$  A source and sink current
- Down to 10 ps jitter
- Fully integrated HV receiver switch
- 13.5  $\Omega$  on resistance
- HV MOS topology to minimize current consumption
- Up to 300 MHz BW
- 2.4 V to 3.6 V CMOS logic interface
- Auxiliary integrated circuits
- Noise blocking diodes
- Fully self-biasing architecture
- Anti-memory effect for all internal HV nodes
- Thermal protection
- Stand by function

- Latch-up free due to HV SOI technology
- Very few external passive components needed

STHV748 应用:

- Medical ultrasound imaging
- Pulse waveform generator
- NDT ultrasound transmission
- Piezoelectric transducers driver

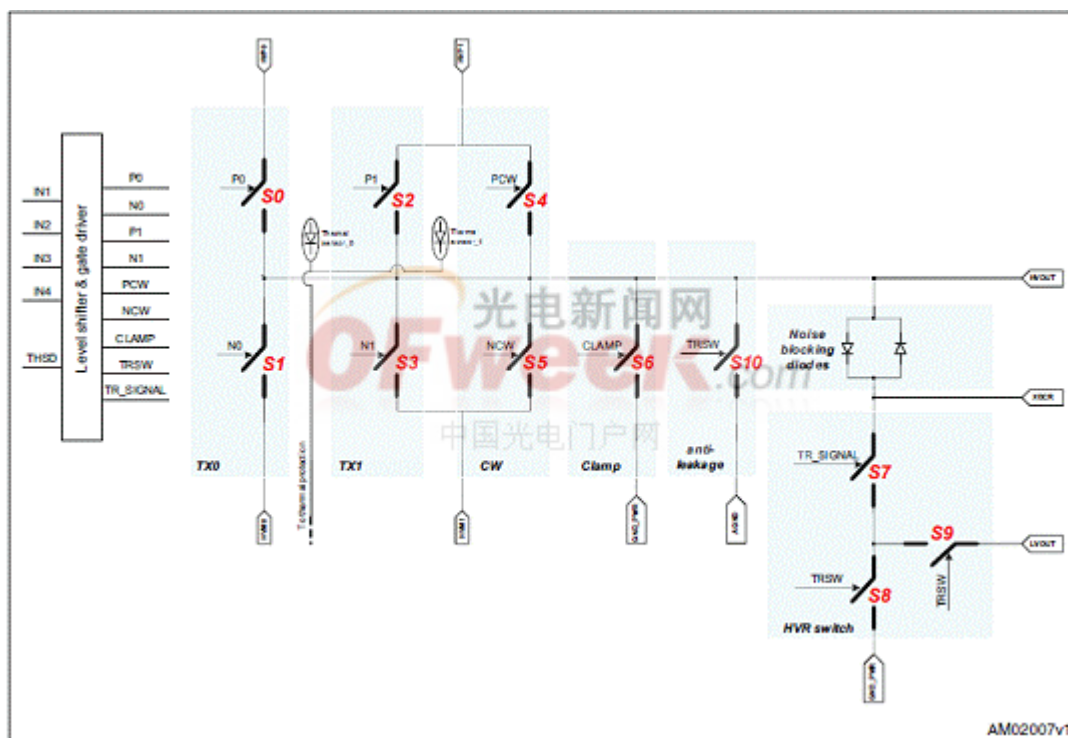

图 1.STHV748 单路方框图

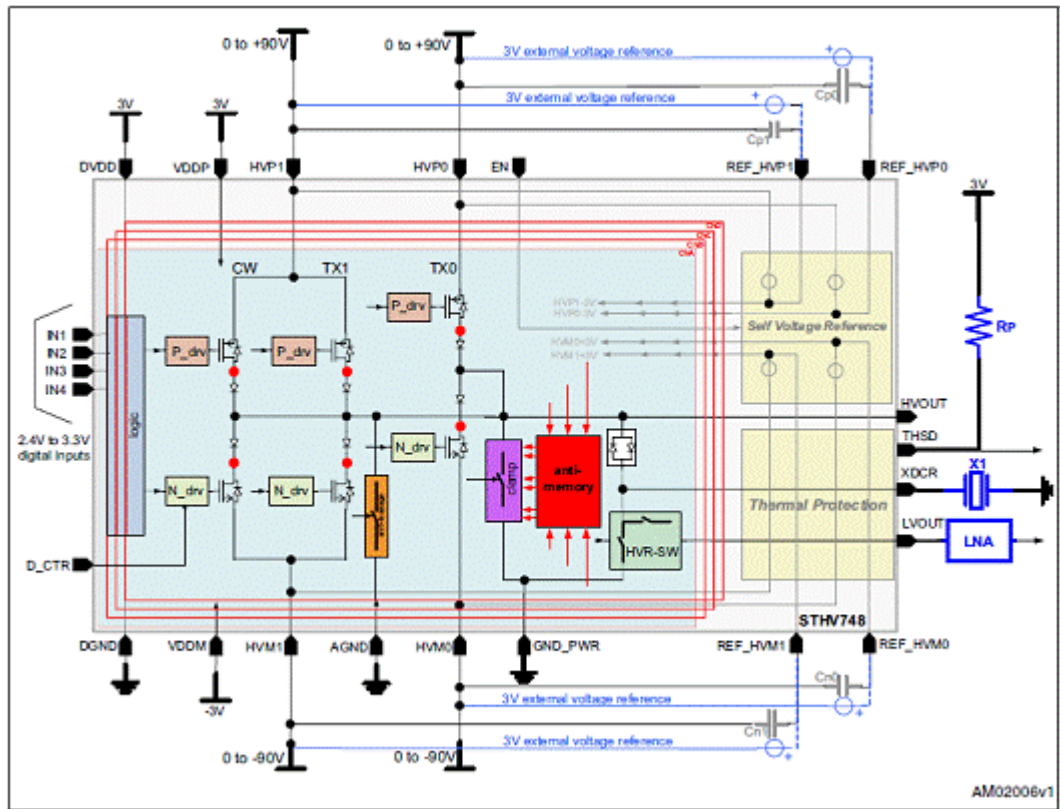

图 2. STHV748 典型应用电路