

OTN (G.709) Reference Guide

Your insight into the optical transport network

**test
expert**

EXFO

EXPERTISE REACHING OUT

About EXFO

EXFO is a recognized test and measurement expert in the global telecommunications industry through the design and manufacture of advanced and innovative solutions as well as best-in-class customer support. The Telecom Division, which represents the company's main business activity, offers fully integrated and complete test solutions to network service providers, system vendors and component manufacturers in approximately 70 countries. One of EXFO's strongest competitive advantages is its PC/Windows-based modular platforms that host a wide range of tests across optical, physical, data and network layers, while maximizing technology reuse across several market segments. The Life Sciences and Industrial Division mainly leverages core telecom technologies to offer value-added solutions in the life sciences and high-precision assembly sectors. For more information about EXFO, visit www.EXFO.com.

About the Author

Ms. Mai Abou-shaban has ten years of telecommunications experience in sales technical support with startup companies and major system vendors mainly Nortel Networks. Mai brings a wealth of international experience supporting major telecommunications accounts in Americas, EMEA and Asia. Mai holds a Bachelor of Electrical Engineering (Telecommunications option) from Concordia University in Montreal.

Table of Contents

1. Introduction	2	5. ODUk Multiplexing	29
2. Optical Transport Network (OTN) Layers	4	6. Testing Optical Transport Network Elements	32
3. G.709 Interfaces and Rates	8	6.1 Interface Specifications Test	33
4. OTU Frame Structure and Overhead	10	6.2 Response Test	34
4.1 Framing	11	6.3 Conformance and Interoperability Test	35
4.2 Overhead	13	6.4 Client Signal Mapping Test	35
4.2.1 Optical Channel Transport Unit (OTU) Overhead	13	6.5 Appropriate FEC Behavior Test	36
4.2.2 Optical Channel Data Unit (ODU) Overhead	16	6.6 ODU1 to ODU2 Multiplexing	37
4.2.3 Optical Channel Payload Unit (OPU) Overhead	24	7. Conclusion	38
4.3 OTU Forward Error Correction (FEC)	27	8. Acronyms	40

1

Introduction



1. Introduction

In today's telecom/datacom environment, network operators are forced to integrate their networks in order to reduce operational expenses (OPEX) and eliminate the additional capital expenditures (CAPEX) generated by multiple parallel networks. Every network operator is therefore attempting to provide the greatest number of services on the leanest possible infrastructure to drive faster returns on investments. For instance, traditional telecom carriers and service providers are now considering deploying new technologies to help meet new market demands and challenges. Examples of such technological changes include implementing broadband access – both wired (e.g., xDSL, FTTx) and wireless (IEEE 802.11); as well as migrating from circuit-switched voice services to voice-over-IP (VoIP) and from ATM- and FDDI-based solutions to Gigabit Ethernet. In addition, there is the added pressure of growing demand for high-capacity, fixed-bandwidth services and the challenge of fulfilling all their requirements.

In response to such changes, the ITU-T developed a set of standards to meet these emerging needs. ITU-T recommendation G.709, *Interface for the optical transport network (OTN)*, is among the latest of these standards, and its aim is to address the transmission requirements of today's wide range of services; namely, it was developed to assist in network evolution to higher bandwidth and improve network performance. Many of the notions in ITU-T G.709 are similar to those in SONET/SDH; e.g., layered structure, in-service performance monitoring, protection and other management functions. However, some key elements have been added to continue the cycle of improved performance and reduced cost. Among these key elements, the ITU-T G.709 provides a standardized way to manage the optical channels in the optical domain without the need to convert the optical signals to electrical signals and apply the forward error correction (FEC) algorithm to improve transmission performance and enable longer optical spans.

Currently, the majority of OTN applications are running on DWDM transport networks. However, products that support OTN standards to various degrees are already available and even more OTN-based product lines and feature sets are expected to hit the market in the very near future.

2

Optical Transport Network (OTN) Layers

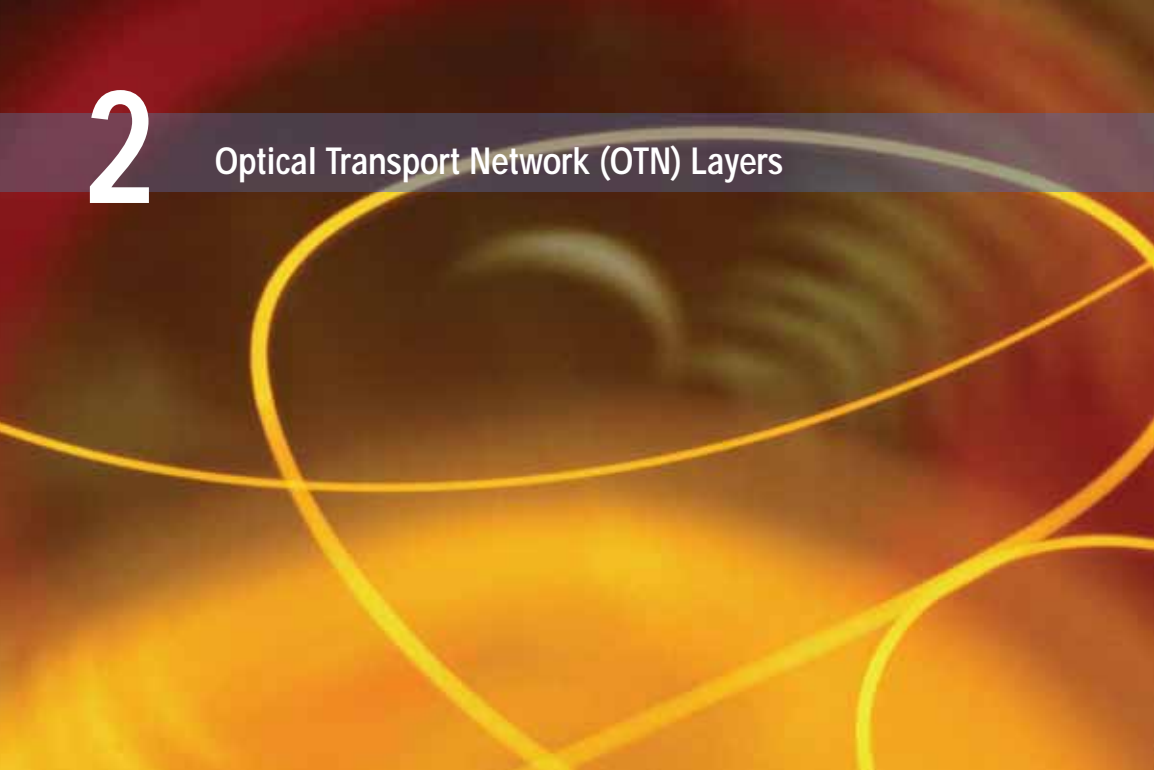

2. Optical Transport Network (OTN) Layers

The optical transport hierarchy (OTH) is a new transport technology for optical transport networks developed by the ITU. It is based on the network architecture defined in various recommendations (e.g., G.872 on architecture; G.709 on frames and formats; and G.798 on functions and processes). OTH combines electrical and optical multiplexing under a common framework. The electrical domain is structured in a hierarchical order just like SONET/SDH, and the optical domain is based on DWDM multiplexing technology but with standardized interfaces and methods to manage the network. ITU-T recommendation G.872, *Architecture for the Optical Transport Network (OTN)*, defines two classes of OTN interfaces (see Figure 2.1- *laDI vs. IrDI interfaces*).

- **OTN inter-domain interface (IrDI):** This interface connects the networks of two operators, or the subnetworks of one or multiple vendors in the same operator domain. The IrDI interface is defined with 3R (reshape, regenerate and retime) processing at each end.
- **OTN intra-domain interface (laDI):** This interface connects networks within one operator and vendor domain.

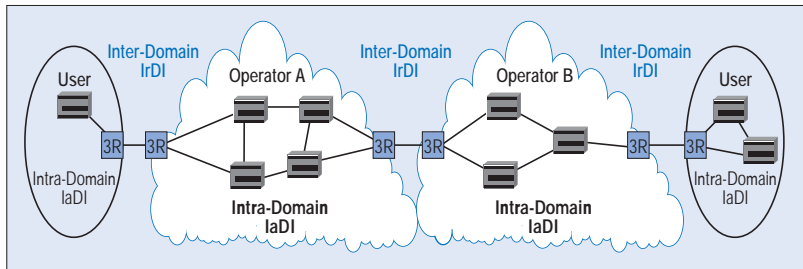

Figure 2.1 – laDI vs. IrDI Interfaces

The ITU G.872 recommendation also defines the optical network architecture based on the optical channel (OCh) carried over a specific wavelength. Different from that of legacy DWDM systems, the structure of this signal is standardized. The OTN architecture is composed of three layers, shown in *Figure 2.2 - OTN Layer Termination Points*, and constructed using the OCh with additional overheads.

- **Optical Channel (OCh)** – represents an end-to-end optical network connection with the encapsulated client signal in the G.709 frame structure.
- **Optical Multiplex Section (OMS)** – refers to sections between optical multiplexers and demultiplexers.
- **Optical Transmission Section (OTS)** – refers to sections between any network elements in the OTN, including amplifiers.

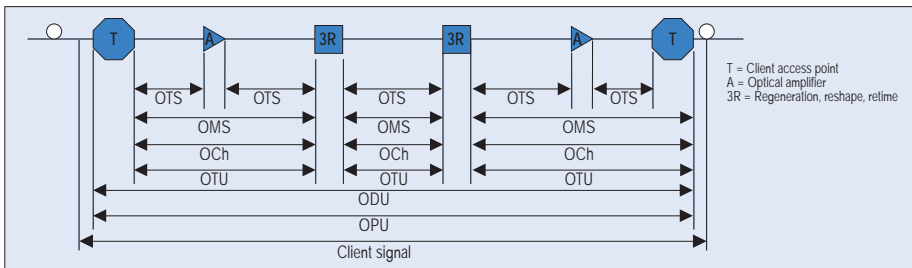

Figure 2.2 – OTN Layer Termination Points

The termination of the OTS, OMS and OCh layers is performed at the optical level of the OTN. The OCh payload consists of an electrical substructure, where the optical channel transport unit (OTU) is the highest multiplexing level. This layer is the digital layer – also known as the “digital wrapper” – which offers specific overhead to manage the OTN’s digital functions. The OTU also introduces a new dimension to optical networking by adding forward error correction (FEC) to the network elements, allowing operators to limit the number of required regenerators used in the network and in turn reduce cost.

The transport of a client signal in the OTN (shown in Figure 2.3 – Basic OTN Transport Structure) starts with the client signal (SONET/SDH, ATM, GFP, etc.) being adapted at the optical channel payload unit (OPU) layer by adjusting the client signal rate to the OPU rate. The OPU overhead itself contains information to support the adaptation process of the client signal. Once adapted, the OPU is mapped into the optical channel data unit (ODU) with the necessary ODU overhead to ensure end-to-end supervision and tandem connection monitoring. Finally, the ODU is mapped into an OTU, which provides framing, as well as section monitoring and FEC.

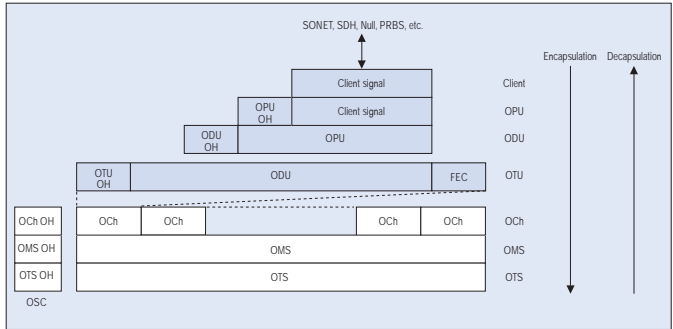

Figure 2.3 – Basic OTN Transport Structure

Each OTU_k (k = 1, 2, 3) is transported using an optical channel (OCh) assigned to a specific wavelength of the ITU grid. Several channels can be mapped into the OMS layer and then transported via the OTS layer. The OCh, OMS and OTS layers each have their own overhead for management purposes at the optical level. The overhead of these optical layers is transported outside of the ITU grid in an out-of-band common optical supervisory channel (OSC). In addition, the OSC provides maintenance signals and management data at the different OTN layers.

3

G.709 Interfaces and Rates

3. G.709 Interfaces and Rates

The ITU-T G.709 recommendation defines standard interfaces and rates based on the existing SONET/SDH rates. When taking into consideration the additional G.709 overhead and FEC information, the resulting interfaces operate at line rates roughly 7% higher than the corresponding SONET/SDH rates. *Table 3.1– G.709 Defined Interfaces* lists the G.709 line rates and their corresponding SONET/SDH interfaces.

G.709 Interface	Line Rate	Corresponding SONET/SDH Rate	Line Rate
OTU1	2.666 Gbit/s	OC-48/STM-16	2.488 Gbit/s
OTU2	10.709 Gbit/s	OC-192/STM-64	9.953 Gbit/s
OTU3	43.018 Gbit/s	OC-768/STM-256	39.813 Gbit/s

Table 3.1 – G.709 Interfaces and Rates

4

OTU Frame Structure and Overhead

4. OTU Frame Structure and Overhead

Figure 4.1 - OTU Frame Structure illustrates the three parts that constitute the optical channel transport unit (OTU) frame:

- Framing (frame alignment signal and multiframe alignment signal)
- OTU, ODU, OPU overhead
- OTU forward error correction

4.1. Framing

When transmitting serial blocks of data in an optical transport system, it is essential for the receiving equipment to identify the block boundaries. The ability to identify the starting point in the OTN is accomplished through the use of framing bytes, which are transmitted in every frame. The OTU framing structure is divided into two portions: frame alignment signal (FAS) and multiframe alignment signal (MFAS), shown in *Figure 4.2 – G.709 Frame Alignment*.

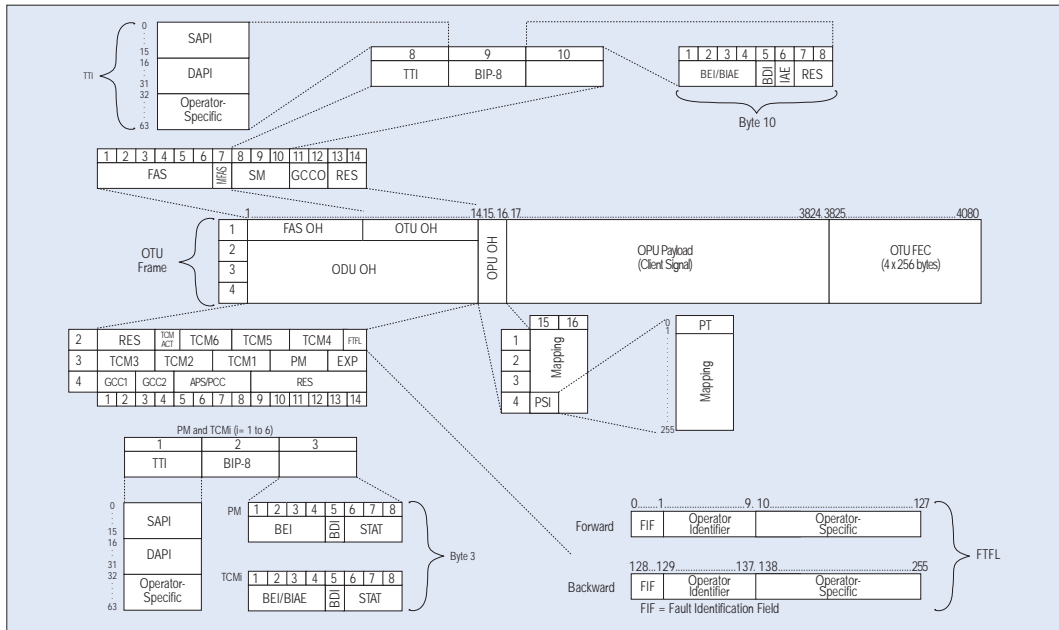

Figure 4.1 – OTU Frame Structure

- **Frame alignment signal (FAS)** – uses the first six bytes in Row 1, Columns 1 to 6. As in SONET/SDH, G.709 uses FAS to provide framing for the entire signal and to identify out-of-frame (OOF) and loss-of-frame (LOF) conditions
- **Multiframe alignment signal (MFAS)** – G.709 supports multiframe structure, in which some of the OTU and ODU overhead signals could span multiple OTU frames. Examples are the trail trace identifier (TTI) and tandem connection monitoring activation (TCM-ACT) overhead signals. A single MFAS byte is used to extend command and management functions over several frames. The MFAS byte is defined in Row 1, Column 7 of the G.709 frame and incremented for each OTU/ODU frame, providing a 256 multiframe structure.

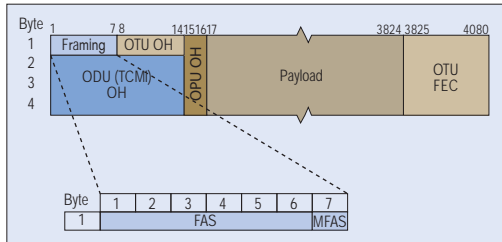

Figure 4.2 – G.709 Frame Alignment

4.2. Overhead

4.2.1. Optical Channel Transport Unit (OTU) Overhead

The OTU overhead is comprised of the SM, GCC0 and RES bytes, shown in *Figure 4.3 – OTU Overhead and SM Structure*.

- **Section Monitoring (SM)** bytes are used for the trail trace identifier (TTI), parity (BIP-8) as well as the backward error indicator (BEI), backward incoming alignment error (BIAE), backward defect indicator (BDI), and incoming alignment error (IAE).
 - *SM trail trace identifier (TTI)* is a one-byte overhead field defined to support 64-byte trace signals. TTI is used to identify a signal from the source to the destination within the network. The TTI contains the so-called access point identifiers (API) field, which is used to specify the source access point identifier (SAPI) and destination access point identifier (DAPI). The APIs contain information regarding the country of origin, network operator and administrative details.

- *SM error bit-interleaved parity-8* (BIP-8) is a one-byte error detection code signal. The OTUK BIP-8 is computed over the OPUk area of a specific frame and inserted in the OTUK BIP-8 overhead two frames later.
- *SM backward defect indication* (BDI) is a single-bit signal defined to convey the signal fail status detected in the upstream direction.
- *SM backward error indication and backward incoming alignment error* (BEI/BIAE) is a four-bit signal used to convey in the upstream direction the number of interleaved-bit blocks detected in error by the section monitoring BIP-8 code. It is also used to convey in the upstream direction an incoming alignment error (IAE) condition that is detected in the section monitoring IAE overhead

- **General Communications Channel (GCC0)** field, which resembles the data communications channel (DCC) in SONET/SDH, is currently undefined, but it will likely be used for functions such as network management or control plane signaling for a protocol like generic multiprotocol label switching (G-MPLS).
- **Reserved (RES)** fields, found throughout the overhead, are set aside for future use.

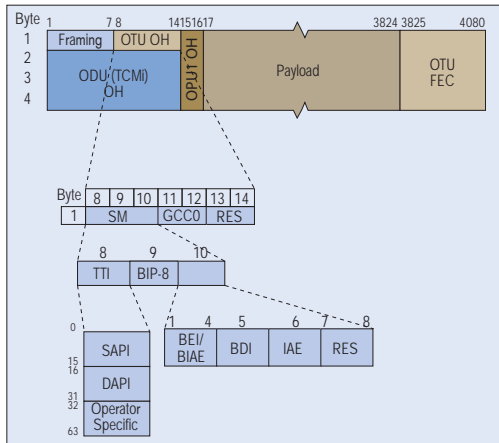

Figure 4.3 – OTU Overhead and SM Structure

Field	Definition	
Section Monitoring (SM)	SM consists of the following bytes; TTI, BIP-8, BEI, BIAE, BDI and IAE	
	Trail Trace Identifier (TTI)	The 64-byte multiframe TTI signal is similar to the J0 byte in SONET/SDH.
	Bit-Interleaved Parity (BIP-8)	The BIP-8 value covers the OPU and client payload of the G.709 frame and its value is inserted in the BIP-8 field of the second frame following calculation.
	Backward Defect Indication (BDI)	When an AIS is sent in the downstream direction as a response to a signal fail indication (such as in the FTFL), the upstream direction response to continuity, connectivity and maintenance signals is a backward defect indication (BDI) signal. BDI is raised as an alarm when it has been received for five consecutive frames.
	Backward Error Indication (BEI) and Backward Incoming Incoming Alignment Error (BIAE)	The detection of a frame slip, which can occur at the OTU, generates an alignment error (IAE) in the downstream direction. The three-bit value of "010" in the Status (STAT) field indicates IAE. A corresponding BIAE is inserted in the upstream direction by specifying bits "1011" in the BEI/BIAE SM field.
	STAT	These three bits indicate the presence of maintenance signals (AIS, OCI, TCMi, IAE).
General Communication Channel 0 (GCC0)	A clear channel used for transmission of information between OTU termination points.	
RES	Reserved bytes that are currently undefined in the standard.	

Table 4.1 – Summary of OTU Overhead Bytes

4.2.2. Optical Channel Data Unit Overhead

The optical channel data unit (ODU) overhead, shown in Figure 4.4 – ODU Overhead and PM/TCMi Structure, supports two classes of ODUk maintenance signals, reported using path monitoring overhead (PMOH) status (STAT) bits and tandem connection monitoring (TCM) STAT bits. Through either PMOH or TCM STAT bits, the following ODU conditions can be reported: alarm indication signal (ODUk-AIS), open connection indication (ODU-OCI), locked (ODUk-LCK), and generic AIS. In addition, the ODUk overhead supports automatic protection switching (APS) functionality. The ODUk overhead is broken into the following fields: RES, PM, TCMi, TCM ACT, FTFL, EXP, GCC1/GCC2 and APS/PCC.

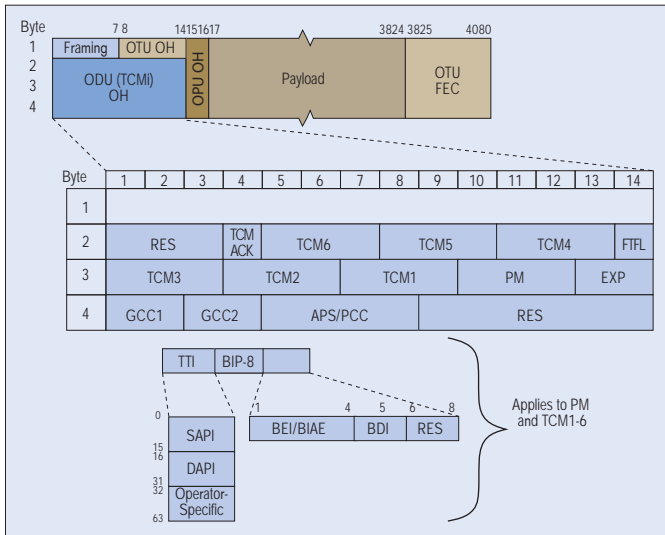

Figure 4.4 – ODU Overhead and PM/TCMi Structure

- **Reserved (RES)** bytes are undefined and are set aside for future applications.
- **Path Monitoring (PM)** enables the monitoring of particular sections within the network as well as fault location in the network. The PM bytes are configured in Row 3, Columns 10 to 12, and contain subfields similar to the ones in SM including: TTI, BIP-8, BEI, BDI and Status (STAT) subfields.
 - *PM trail trace identifier (TTI)* is a one-byte overhead field similar to the J0 byte in SONET/SDH. It is used to identify the signal from the source to the destination within the network. The TTI contains the so-called access point identifiers (API) field, which is used to specify the source access point identifier (SAPI) and destination access point identifier (DAPI). The APIs contain information regarding the country of origin, network operator and administrative details.
 - *PM bit-interleaved parity (BIP-8)* is a one-byte field, which is used for error detection. The BIP-8 byte provides a bit-interleaved parity – eight-bit code computed over the whole OPU and inserted into the BIP-8 SM two frames later.
 - *PM backward defect indication (BDI)* is a single bit, which conveys information regarding signal failure in the upstream direction.
 - *PM backward error indication (BEI)* and backward incoming alignment error (BIAE) signals carry information on interleaved-bit blocks detected in error in the upstream direction. These fields are also used to convey incoming alignment errors (IAE) in the upstream direction.
 - *PM status (STAT)* is a three-bit field used to indicate the presence of maintenance signals.
- **Tandem Connection Monitoring (TCMi)** fields, which are part of the ODU overhead, define six ODU TCM sublayers. Each TCM sublayer contains a TTI, BIP-8, BEI/BIAE, BDI and STAT subfield associated with a TCMi level ($i = 1$ to 6).
- **Tandem Connection Monitoring Activation/Deactivation (TCM ACT)** is a one-byte field located in Row 2, Column 4. TCM ACT is currently undefined in the standard.
- **Fault Type and Fault Location (FTFL)** is a one-byte field located in Row 2, Column 14 of the ODU overhead and is used to transport a fault type and fault location (FTFL) message, spread over a 256-byte multiframe for sending forward and backward path-level fault indications (shown in *Figure 4.5 – FTFL Field Structure*). The forward field is allocated to bytes 0 through 127 of the FTFL message. The backward field is allocated to bytes 128 through 255 of the FTFL message.

- **Experimental (EXP)** is a two-byte field located in Row 3, Columns 13 and 14 of the ODU overhead. The EXP field is not subject to standards and is available for network operators to support applications that may require additional ODU overhead.

- **General Communication Channels 1 and 2 (GCC1/GCC2)**

(GCC1/GCC2) are two fields of two bytes each, and they support general communication channels between any two network elements; similar to the GCC0 field, except that they are available in the ODU overhead. GCC1 is located in Row 4 and Columns 1 and 2 and GCC2 is located in Row 4, Columns 3 and 4 of the ODU overhead.

- **Automatic Protection Switching and Protection Communication Channel (APS/PCC)** is a four-byte signal defined in Row 4, Columns 5 to 8 of the ODU overhead. The APS/PCC field supports up to eight levels of nested APS/PCC signals, which are associated with dedicated-connection monitoring.

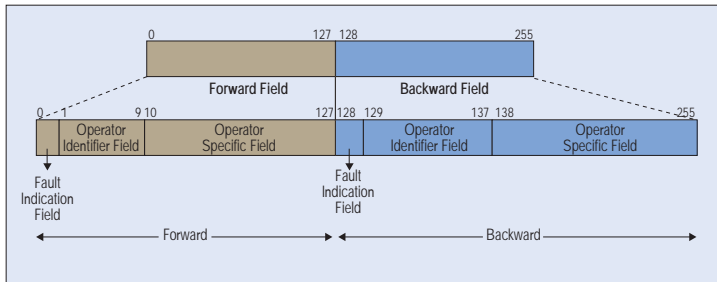

Figure 4.5 – FTL Field Structure

Field	Definition	
Path Monitoring	PM consists of the following bytes; TTI, BIP-8, BEI, BIAE, BDI and IAE.	
	Trail Trace Identifier (TTI)	The 64-byte multiframe TTI signal is similar to the J0 byte in SONET/SDH.
	Bit-Interleaved Parity (BIP-8)	The ODU PM contain a BIP-8 field that covers the OPU and client payload of the G.709 frame. The BIP-8 values are inserted in the BIP-8 field of the frame following calculation.
	Backward Defect Indication (BDI)	The AIS – forwarded signal in the downstream direction – is sent as a response to a signal fail indication, such as in the FTFL or the incoming ODU-AIS. In the upstream direction, the response to continuity, connectivity and maintenance signals is a backward defect indication (BDI) signal indicated by a bit found in the PM and TCMi. BDI is raised as an alarm when it has been received for five consecutive frames.
	Backward Error Indication (BEI) and Backward Incoming Incoming Alignment Error (BIAE)	The AIS – forwarded signal in the downstream direction – is usually sent as a response to a signal fail indication, such as in the FTFL or the incoming ODU-AIS. In the upstream direction the response to continuity, connectivity and maintenance signals is a BDI signal indicated by a bit found in the PM and TCMi. BDI is raised as an alarm when it has been received for five consecutive frames.
	STAT	These three bits indicate the presence of maintenance signals (AIS, OCI, TCMi, IAE)

Table 4.2 – Summary of ODU Overhead Bytes (continued on page 19)

Tandem Connection Monitoring (TCM)	Six TCM sublayers are defined in the ODU overhead. Each TCM sublayer contains a TTI, BIP-8, BEI/BIAE, BDI and STAT subfields.
Tandem Connection Monitoring Activation/Deactivation (TCM ACT)	One-byte field used for the activation and deactivation of the TCM fields. This field is currently undefined in the standard.
Fault Type and Fault Location (FTFL)	Reporting communication channel field that is used to create a message for sending forward and backward path-level fault indications
Experimental (EXP)	This field is not subject to standards and is available for network operator applications.
General Communication Channel 1 and 2 (GCC1/GCC2)	Clear channels used for transmission of information at the ODU layer; similar to the GCC0.
Automatic Protection Switching and Protection Communication Channel (APS/PPC)	This field supports up to eight levels of nested APS/PCC signals, which are associated to a dedicated-connection monitoring level
RES	Reserved bytes that are currently undefined in the standard.

Table 4.2 – Summary of ODU Overhead Bytes (continued)

- Tandem Connection Monitoring (TCM)** has been implemented in SONET/SDH networks to enable carriers to monitor the quality of the traffic across multiple networks. This has been achieved by breaking the path into a series of tandem paths, each owned and managed by individual network operators. Errors and defects along the path can be traced to a particular tandem path for fast and easy troubleshooting. *Figure 4.6 – Tandem Connection Monitoring* shows an example of a small network operator (Operator B) that is leasing network resources from a larger network operator (Operator A) rather than install its own networks. Operator A requires the ability to monitor the transmitted signal as it passes through Operator B's network. Should a fault develop in the network, using tandem connection monitoring, Operator A can quickly identify whether the fault is located in Operator B's network, or further along the tandem path with another operator. In addition, different monitoring functions can be assigned to different connections. For example in *Figure 4.6 – Tandem Connection Monitoring (TCM)*, TCM1 is assigned to monitor the end-to-end quality of service (QoS), TCM2 is used by Operator A to monitor their end-to-end QoS, and finally TCM3 is used for various domains and domain-interconnect monitoring.

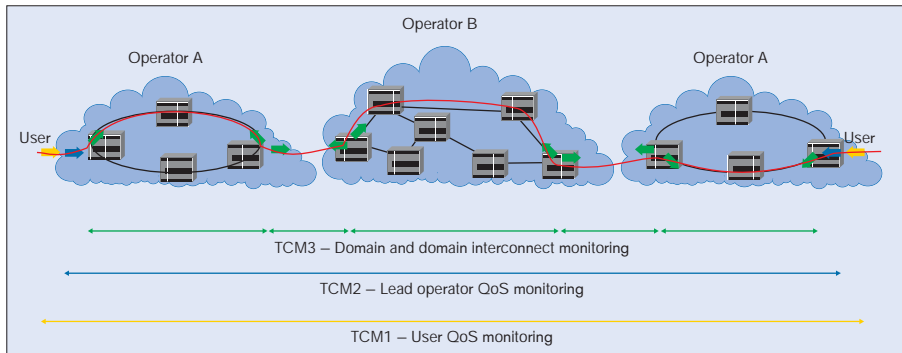

Figure 4.6 – Tandem Connection Monitoring (TCM)

In optical transport networks, each one of the six TCM_i fields has the same structure as the PM field, including the following subfields: TTI, BIP8, BDI, BEI, status bits, indicating the presence of incoming alignment error (IAE), or a maintenance signal (STAT). Optical transport networks support three TCM topologies, as shown in *Figure 4.7 – OTN Tandem Connection Monitoring (TCM) Topologies*. Figure 4.7a shows tandem connections C1-C2, B1-B2, and A1-A2 in nested configuration. Figure 4.7b shows tandem connections B1-B2 and B3-B4 in cascaded configuration. Finally, Figure 4.7c shows tandem connections B1-B2 and C1-C2 in overlapping configuration.

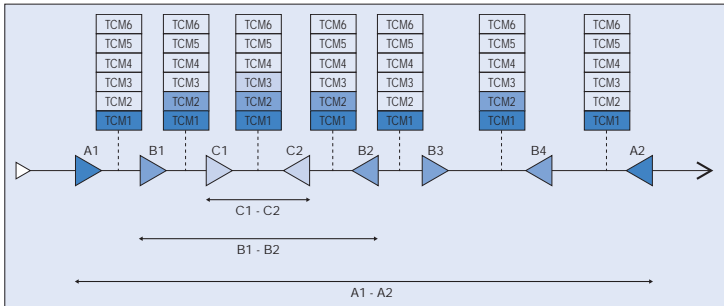

Figure 4.7a – TCM Topologies: Nested

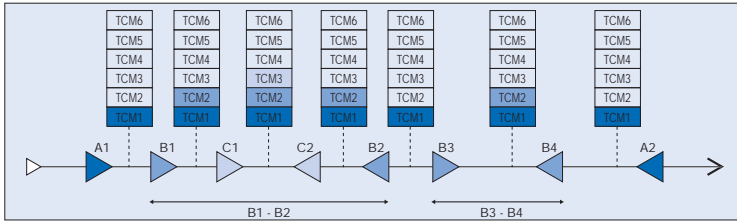

Figure 4.7b – TCM Topologies: Cascaded

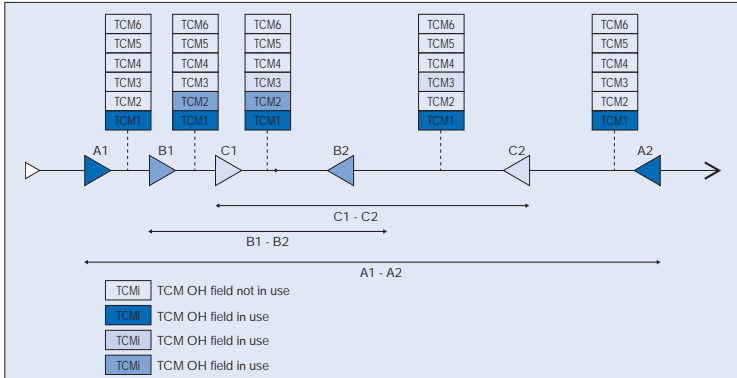

Figure 4.7c – TCM Topologies: Overlapping

4.2.3. Optical Channel Payload Unit (OPU) Overhead

The ITU-T G.709 standard currently defines mappings for constant-bit-rate signals, both bit-synchronous and asynchronous. This includes SONET/SDH, ATM, generic framing procedures (GFP) and pseudo-random bit sequence (PRBS) patterns. As part of the G.709 encapsulation process, the OPU overhead is added to support the adaptation of the various client signals.

The OPU overhead is located in Rows 1 to 4 of Columns 15 and 16, and it is terminated where the OPU is assembled and disassembled. The OPU overhead consists of the following fields:

- **Payload Structure Identifier (PSI)** is a one-byte field allocated in the OPU overhead to transport a 256-byte payload structure identifier (PSI) signal. The PSI byte is located in Row 4, Column 15 of the OPU overhead.
- **Payload Type (PT)** is a one-byte field defined in the PSI[0] byte and contains the PT identifier that reports the type of payload being carried in the OPU payload to the receiving equipment. *Table 4.3* includes all possible payload type values currently defined by the ITU-T G.709 standard.

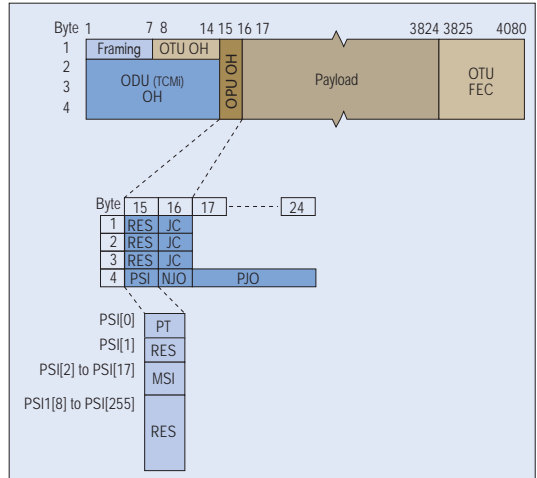

Figure 4.8 – OPU Overhead and PSI Field Structure

MSB 1 2 3 4	LSB 5 6 7 8	Hex code (Note 1)	Interpretation
0 0 0 0	0 0 0 1	01	Experimental mapping
0 0 0 0	0 0 1 0	02	Asynchronous CBR mapping
0 0 0 0	0 0 1 1	03	Bit-synchronous CBR mapping
0 0 0 0	0 1 0 0	04	ATM mapping
0 0 0 0	0 1 0 1	05	GFP mapping
0 0 0 0	0 1 1 0	06	Virtual concatenated signal
0 0 0 1	0 0 0 0	10	Bit stream with octet timing mapping
0 0 0 1	0 0 0 1	11	Bit stream without octet timing mapping
0 0 1 0	0 1 1 0	20	ODU multiplex structure
0 1 0 1	0 1 0 1	55	Not available
0 1 1 0	0 1 1 0	66	Not available
1 0 0 0	x x x x	80-8F	Reserved codes for proprietary use
1 1 1 1	1 1 0 1	FD	NULL test signal mapping
1 1 1 1	1 1 1 0	FE	PRBS test signal mapping
1 1 1 1	1 1 1 1	FF	Not available

Table 4.3 – Payload Type (PT) Defined Values

- **Multiplex Structure Identifier (MSI)** field is used to encode the ODU multiplex structure in the OPU and is located in the mapping-specific area of the PSI signal (PSI[2] to PSI[17]). The MSI indicates the content of each tributary slot (TS) of an OPU.
- **Justification Control (JC)** overhead consists of justification control (JC), negative justification opportunity (NJO) and positive justification opportunity (PJO) signals used in the ODU multiplexing process. The justification overhead bytes are used to make the justification decision in the mapping/demapping process of the client signal to protect against an error in one of the three JC signals.

Field	Definition
Payload Structure Identifier (PSI)	Defined to transport a 256-byte message aligned with MFAS.
Payload Type (PT)	Contains the payload type (PT) identifier that reports the type of payload being carried in the OPU payload to the receiving equipment field, and it is currently undefined in the standard.
Multiplex Structure Identifier (MSI)	Located in the mapping-specific area of the PSI signal (PSI[2] to PSI[17]), and it is used to encode the ODU multiplex structure in the OPU.
Justification Control (JC)	Justification control (JC), negative justification opportunity (NJO) and positive justification opportunity (PJO) signals are used in the ODU multiplexing process to make the justification decision in the mapping/demapping process of the client signal.

Table 4.4 – Summary of OPU Overhead Bytes

4.3. OTU Forward Error Correction (FEC)

Forward Error Correction (FEC) is a major feature of OTN. It uses a Reed-Solomon RS (255,239) algorithm code to produce redundant information that gets concatenated with the transmitted signal and used at the receive interface to help identify and correct transmission errors. The FEC algorithm has been proven to be effective in systems limited by optical signal-to-noise ratio (OSNR) and dispersion. However, FEC is less effective against polarization mode distortion.

Figure 4.9 - BER vs. E_b/N_0 compares a transport system performance with and without FEC (G.709). Figure 4.9 shows that the transport system with FEC capabilities is able to transmit a signal at a certain bit error rate (BER) with less power (approximately 6 dB) than one without FEC.

In the transmission process according to the RS (255, 239) FEC algorithm, the OTU frame data is separated into four rows and each row split into 16 subrows, as shown in Figure 4.10.

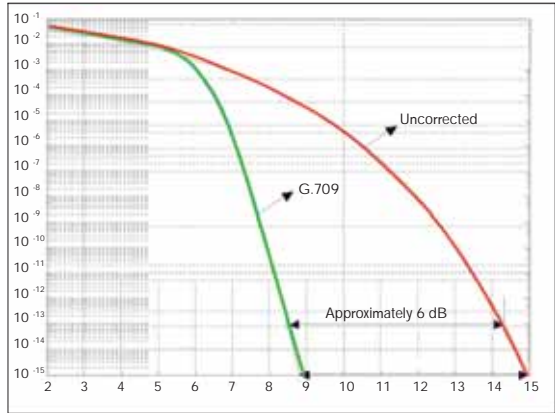

Figure 4.9 - BER vs. E_b/N_0

Figure 4.11 – Forward Error Correction (FEC) Mechanism illustrates the process in which the FEC protocol is interleaving one overhead byte and 238 data bytes to compute 16 parity bytes to form 255-byte blocks; i.e., the RS (255,239) algorithm. The key advantages of interleaving the information are to reduce the encoding rate of each stream relative to the line transmission rate and reduce the sensitivity to bursts of error. The interleaving, combined with the inherent correction strength of the RS (255,239) algorithm, enables the correction of transmission bursts of up to 128 consecutive errored bytes.

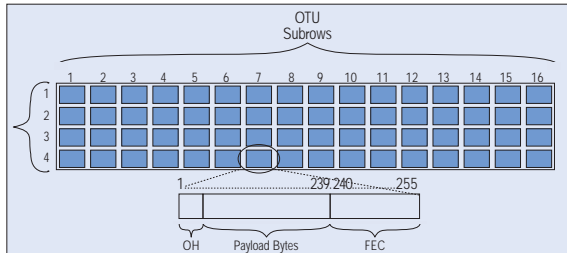

Figure 4.10 – OTU Frame Rows

The coding gain provided by the FEC is used to increase the maximum span length and/or the number of spans, resulting in an extended reach through gain in power level. It also helps increase the number of DWDM channels in a DWDM system and allows the usage of existing 2.5 Gbit/s links to transport 10 Gbit/s traffic. This is in addition to increasing the number of transparent optical network elements that can be crossed by an optical path before amplification is needed. Finally, OTN technology is allowing today's point-to-point links to evolve into transparent and more efficient meshed optical networks.

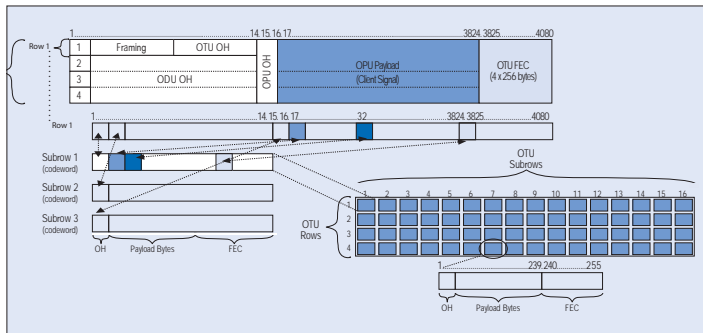

Figure 4.11 – Forward Error Correction (FEC) Mechanism

5

ODUk Multiplexing

5. ODUk Multiplexing

OTN (G.709) has also defined the multiplexing functions that allow four ODU1s to be multiplexed to an ODU2 and up to sixteen ODU1s, or four ODU2s, to be multiplexed to an ODU3. It is also possible to mix ODU1s and ODU2s in an ODU3. The ODU multiplexing function is essential for optimizing the network resources, including bandwidth usage. Typically, client signals consisting of 2.5 Gbit/s bit streams are transported over a single DWDM wavelength. This might be an efficient service-delivery method if distances are short. However, if such services need to be transported over long distances, it is quite expensive to use a dedicated wavelength.

The G.709 recommendation defines the optical payload unit (OPU), which provides the overhead needed to support the ODU multiplexing function. To multiplex four ODU1s into ODU2, the OPU2 is divided into a number of tributary slots (TS) interleaved within the OPU2, as shown in *Figure 5.1 – ODU1 Multiplexing to ODU2*. Each OPU2 tributary slot occupies 25% of the OPU2 payload area. In the multiplexing process, the bytes of an ODU1 input are mapped into one of the four OPU2 tributary slots. The multiplex structure identifier (MSI) is used to define the type of multiplexing that is implemented at the transmitter. The MSI is made of PSI Bytes 2 to 17, but when multiplexing ODU1 in ODU2, only Bytes 2 to 5 have a meaning; Bytes 6 to 17 are set to 0, as they are intended for multiplexing applications with ODU3. The information carried by the MSI is as follows:

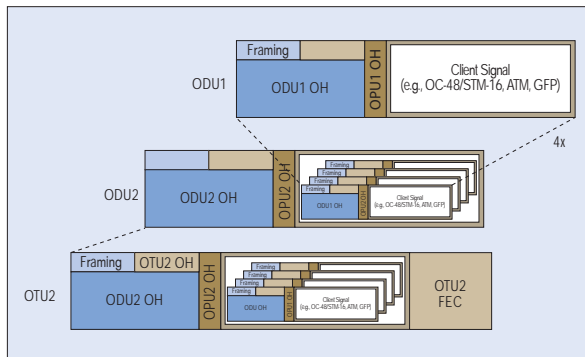

Figure 5.1 – ODU1 Multiplexing to ODU2n

- ODU type carried by the OPU tributary slots (for example, ODU1 in an OPU2 tributary slot)
- Tributary port to tributary slot assignment (for example, Tributary Port 1 mapped to OPU2 Tributary Slot 1)

In the case of ODU1 in ODU2, the tributary-port-to-tributary-slot assignment is fixed, which means that Tributary Port 1 is assigned to Tributary Slot 1 and so on. Finally, an ODU2 overhead is added, after which the ODU2 is mapped into the OTU2 to complete the signal for transport.

The ODU multiplexing functionality of four OC-48/STM-16 signals in one OTU2 is both bit and timing-transparent. This ensures that the integrity of the whole client signal is maintained and the input timing of a synchronous signal is transferred to the far end. ODU multiplexing is also delay-transparent. When four OC-48/STM-16 signals are mapped into ODU1s and then multiplexed into an ODU2, their timing relationship is preserved until they are demapped back to ODU1s at their destinations.



6

Testing Optical Transport Network Elements

6. Testing Optical Transport Network Elements

Of course, as with every type of network, testing always ensures optimum performance. Among the tests that should be carried out in order for OTN equipment to comply with ITU-T G.709 and ITU-T G.798 are the following:

- Interface Specifications Test
- Response Test
- Conformance and Interoperability Test
- Mapping/Demapping of Client Signals Test
- Appropriate FEC Behavior Test
- ODU1 to ODU2 Multiplexing

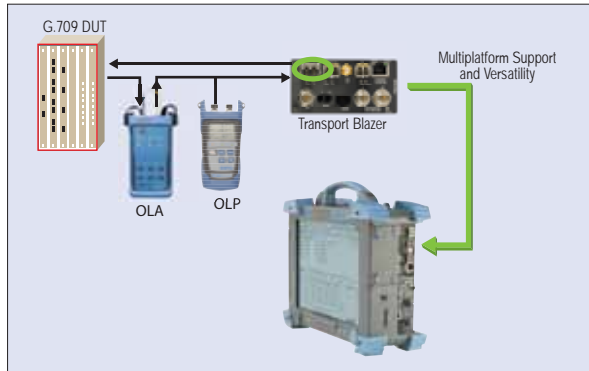

Figure 6.1 – Interface Specifications Test Configuration

6.1. Interface Specifications Test

The interface specifications test is essential to ensure the proper interoperability of equipment from single as well as multiple vendors. The main objective of this test is to verify the input parameters of all interfaces of the G.709 network element under test, including the appropriate OTUk rate, and ensure that synchronization recovery can be properly achieved.

In the interface specification test configuration shown in *Figure 6.1 – Interface Specifications Test Configuration*, the synchronization to the incoming signal must first be checked. For example, clock deviation has to be checked for OTU1 and OTU2 interfaces to ensure it's within the defined ± 20 ppm value.

Additional tests like optical power sensitivity can also be achieved using an optical attenuator to reduce the optical power until the threshold of the input receiver is reached and an optical power meter can be used to measure the minimum supported optical input power.

6.2. Response Test

The network element response test involves sending a stimulus (error or alarm) signal into the device under test (DUT) and monitoring its appropriate output and proper consequence. In OTN, a single stimulus may result in several simultaneous responses. The example shown in *Figure 6.2 – DUT Response Test Configuration* illustrates the test setup and expected responses to a detected loss of signal (LOS) at the receiver.

The response test must be repeated for all possible input stimuli that the DUT is expected to respond to. A list of possible stimuli and their corresponding responses (Alarm/Error) by the network element under test in upstream and downstream directions are shown in Table 6.1.

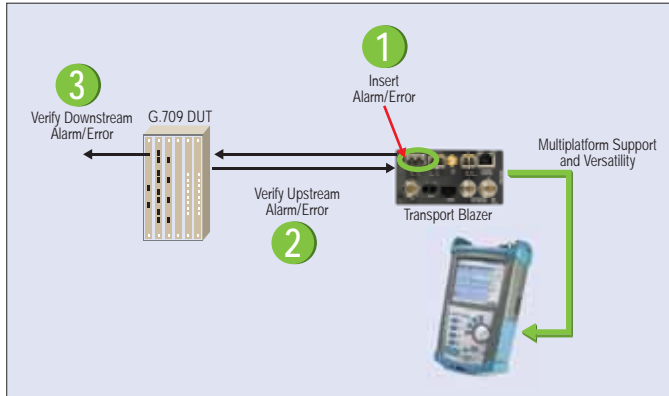

Figure 6.2 – DUT Response Test Configuration

6.3. Conformance and Interoperability Test

The ITU conformance and interoperability test determines the DUT's ability to detect various events under the correct stimulation and standard-specified period of time. Standards normally define entry and exit criteria for alarm events, usually specified by a number of frames or sometimes in a time period. In a similar configuration to the DUT response test shown in *Figure 6.2*, it is recommended to simulate a stimulus condition (alarm/error) over variable test periods. This allows an alarm condition to be simulated for a variable number of frames and to confirm that the entry and exit criteria are met precisely.

6.4. Client Signal Mapping Test

The optical transport hierarchy standard has been designed to transport a range of synchronous and asynchronous payloads. Using OTN decoupled mode, as shown in *Figure 6.3 – Client Signal Mapping Test Configuration*, allows the user to generate a SONET/SDH client signal in the transmit direction and verify the received OTN signal with the mapped SONET/SDH client signal. This configuration enables the test equipment to determine if the DUT successfully recovers the OPU payload under the mapping specifications. When mapping SDH/SONET signal into the OPU, rate differences between the client signal and the OPU clock are accommodated through the use of justification (stuffing) bytes.

Stimulus	Upstream Alarm/Error	Downstream Alarm/Error
LOS-P, LOF, AIS-P, LOM	OTU BDI	OTU-AIS
OTU BIP-8	OTU BEI	-
OTU TIM	OTU BDI	OTU-AIS
OTU IAE	OTU BIAE	-
ODU AIS	ODU BDI	ODU AIS
ODU BIP-8	ODU BEI	-
ODU TIM	ODU BDI	-
ODU OCI	ODU BDI	ODU AIS
ODU PLM	-	ODU AIS

Table 6.1 – Stimulus and DUT Response

The demapping process of a client signal can also be verified in the opposite direction. Using the OTN decoupled mode again, the test equipment can be used to generate an OTN signal with a mapped SONET/SDH client signal on the transmit side and verify the demapped SONET/SDH client signal at the transponder under test.

6.5. Appropriate FEC Behavior Test

As forward error correction (FEC) is a key element of OTN and is used for improving the quality of service, it needs to be validated as part of the G.709 testing. In order to determine the appropriate FEC behavior of the DUT, the test equipment would be used to generate correctable or uncorrectable errors, which would be transmitted through the OTN network element. At the receiving end, the received OTN signal is checked to determine whether or not the errors were corrected or at least detected by the DUT.

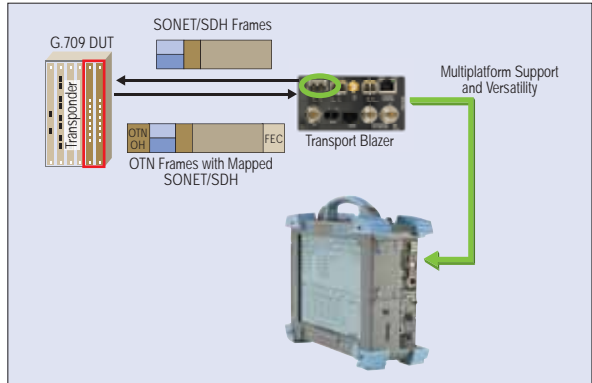

Figure 6.3 – Client Signal Mapping Test Configuration

This test is performed, as shown in *Figure 6.4 – Appropriate FEC Behavior Test Configuration*, by inserting varying numbers of errors distributed over the FEC portion of the OTN frame and checking the error-correction capability of the DUT. This facilitates the discovery of unexpected behavior without affecting the traffic. An advanced FEC behavior test can be performed by distributing correctable errors at random over the entire OTN frame, which should be recovered by the DUT. If not, then the payload will be affected in this case.

6.6. ODU1 to ODU2 Multiplexing

ODU1 to ODU2 multiplex functionality testing is also a key parameter that needs to be validated as part of G.709. In order to determine the appropriate multiplexing capability of the network element under test, the test equipment is used in OTN decoupled mode to generate either an OC-48/STM-16 signal or an OTU1 signal on the transmit side. The transmitted signal then gets multiplexed within an ODU2 signal on the G.709 network element with the proper overhead and FEC bandwidth to compose the final OTU2 signal. Finally, the received OTU2 signal is checked at the test equipment to verify the ODU1 to ODU2 multiplexing with the proper with frequency justification and synchronization as shown in *Figure 6.5 – ODU1 to ODU2 Multiplexing Test Configuration*.

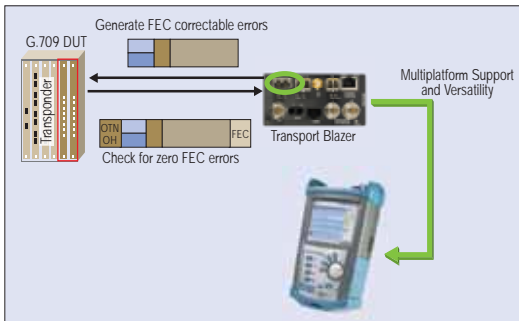

Figure 6.4 – Appropriate FEC Behavior Test Configuration

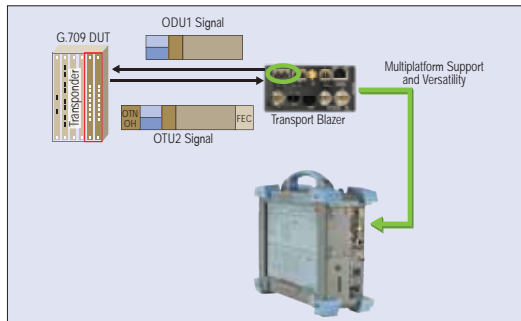

Figure 6.5 – ODU1 to ODU2 Multiplexing Test Configuration

7

Conclusion

7. Conclusion

To satisfy the growing demand for bandwidth, control costs and still remain competitive, service providers are deploying the next-generation optical transport networks defined by ITU-T G.709. The G.709 technology includes forward error correction and enhanced network management, delivering a function comparable to the effect of SONET/SDH on a single wavelength with full transparency.

Today, service providers are faced with the challenge of building up their confidence in the new OTN network and its promised improved performance to the end users. This is made possible with the introduction of the G.709 testing capabilities in the test and measurement market. Service providers are now equipped with the full spectrum of G.709 testing equipment for lab standardization, interoperability testing, field deployment and troubleshooting.

The background features a dark, reddish-brown gradient with a large, glowing yellow sphere in the center. Several bright yellow, glowing lines swirl around the sphere, creating a sense of motion and depth. A horizontal grey bar is positioned across the lower third of the image, containing the page number and title.

8

Acronyms

8. Acronyms

A

APS: Automatic Protection Switching

AIS: Alarm Indication Signal

B

BDI: Backward Defect Indication

BEI: Backward Error Indication

BIP-8: Bit-Interleaved Parity-8

BIAE: Backward Incoming Alignment Error

D

DAPI : Destination Access Point Identifier

DUT : Device Under Test

DWDM: Dense Wavelength-Division Multiplexing

DW: Digital Wrapper

E

EXP: Experimental

F

FEC: Forward Error Correction

FTFL: Fault Type Fault Location

FAS: Frame Alignment Signal

G

GFP: Generic Framing Procedure

GCC: General Communication Channel

I

IaDI: Intra-Domain Interface

IrDI: Inter-Domain Interface

IAE : Incoming Alignment Error

L

LOF: Loss of Frame

LOS: Loss of Signal

LCK: Locked

M

MFAS: Multiframe Alignment Signal

N

NE: Network Element

O

OCh: Optical Channel

OH: Overhead

OLA: Optical Attenuator

OLP: Optical Power Meter

OPU: Optical Channel Payload Unit

OTN: Optical Transport Network

OTU: Optical Channel Transport Unit

OMS: Optical Multiplexing Section

OTS: Optical Transmission Section

OSC: Optical Supervisory Channel

ODU: Optical Channel Data Unit

OAM&P: Operations, Administration, Maintenance & Provisioning

OADM: Optical Add/Drop Multiplexer

OOF: Out of Frame

OOM: Out of Multiframe

OCI: Open Connection Indication

OSNR: Optical Signal-to-Noise Ratio

P

PSI: Payload Structure Identifier

PCC: Protection Communication Channel

PM: Performance Monitoring

PT: Payload Type

PRBS: Pseudo-Random Bit Sequence

PMD: Polarization Mode Distortion

R

RS: Reed Solomon

RES: Reserved

S

SAPI: Source Access Point Identifier

SM: Section Monitoring

SONET: Synchronous Optical Network

SDH: Synchronous Digital Hierarchy

STAT: Status

T

TCM: Tandem Connection Monitoring

TTI: Trail Trace Identifier

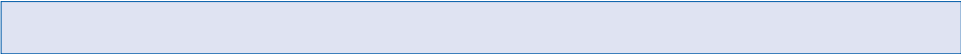

No part of this guide may be reproduced in any form
or by any means without the prior written permission of EXFO.

Printed and bound in Canada

ISBN 1-55342-008-X

Legal Deposit–National Library of Canada 2007

Legal Deposit–National Library of Quebec 2007



LOOP/DSL.1AN 07/03

Unit price: US\$19,95



For details on any of our products and services, or to download technical and application notes, visit our website at www.EXFO.com.

EXFO

EXPERTISE REACHING OUT